



CUSTOM CRIMP™

Innovating SMART Hose Assembly Solutions Since 1979



D165M SERIES HYDRAULIC CRIMPERS OPERATORS MANUAL



CUSTOM CRIMP™

Innovating **SMART** Hose Assembly Solutions Since 1979



SAFETY PRECAUTIONS



- READ INSTRUCTIONS AND IDENTIFY ALL COMPONENT PARTS BEFORE USING CRIMPER.
- D165 SERIES CRIMPERS CAN PRODUCE 62 TONS OF CRIMPING FORCE.
- KEEP BOTH HANDS AWAY FROM PINCH POINTS.
- CONSULT HOSE AND FITTING MANUFACTURER FOR CORRECT MACHINE SETTINGS AND CRIMP MEASUREMENTS.
- ALWAYS WEAR EYE PROTECTION.



CUSTOM CRIMP™

Innovating **SMART** Hose Assembly Solutions Since 1979

TABLE OF CONTENT

SAFETY PRECAUTIONS-----	2
COMPONENT PARTS & TECHNICAL DATA-----	4
AVAILABLE D105 / D165 D-SERIES DRAWER ASSEMBLY / STAND-----	5
FEATURES-----	6
INITIAL SET UP-----	7
LUBRICATION PROCEDURE-----	9
CRIMPING WITH STANDARD COMPRESSION RING-----	10
CRIMPING WITH NOTCHED COMPRESSION RING-----	15
CALIBRATION CHECK PROCEDURE-----	19
D105 / D165 D-SERIES DRAWER ASSEMBLY / STAND (INSTRUCTIONS)-----	22
INCLUDED ACCESSORIES-----	23
AVAILABLE ACCESSORIES-----	24
TROUBLESHOOTING-----	25
COMPONENT PARTS BREAKDOWN-----	26
CUSTOM CRIMP® “NO-NONSENSE” WARRANTY STATEMENT-----	31
CUSTOM CRIMP® CONTACT INFORMATION-----	32



CUSTOM CRIMP™

Innovating SMART Hose Assembly Solutions Since 1979

COMPONENT PARTS & TECHNICAL DATA

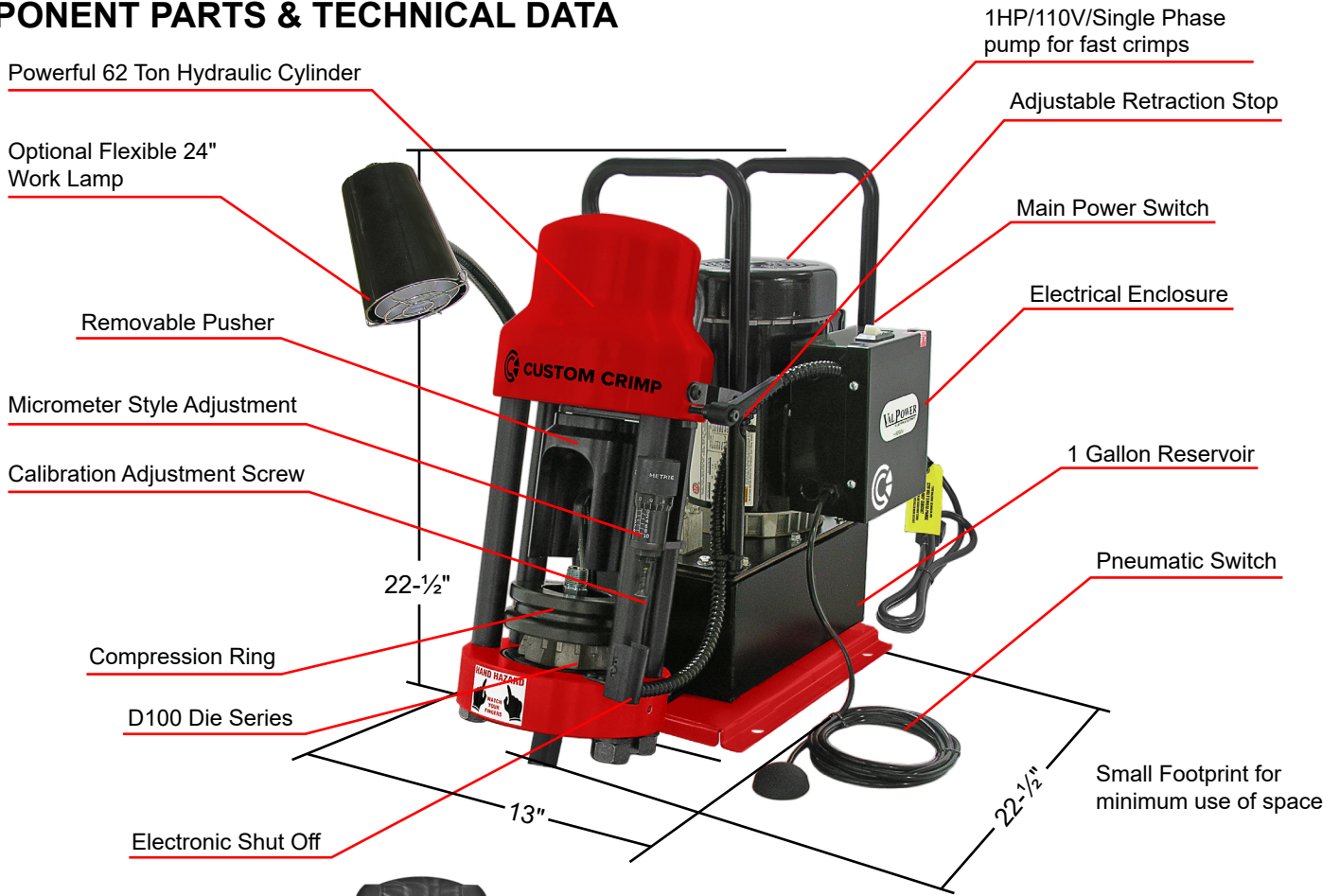

D160/D165 Pusher w/ Magnets

Standard D160/D165 Compression Ring

D100 Die Series

D160/D165 Pressure Plate



D165M Technical Specifications	
Crimping Force: 62 Ton	
Hydraulic Hose Capacity: 2 Wire = 1-1/4" 4 Spiral = 1-1/4" 6 Spiral = 1"	
Crimper Size: L: 22-1/2" x W: 13" x H: 22-1/2"	
Crimper Weight: 140 lbs	
Power: 1HP/110V/1Phase (Standard) 2HP/220V/1Phase (Optional)	
Micrometer Style Adjustment: Metric	
Die series: D100	
Reservoir capacity: 1 US Gallon	
Oil type: ISO 46 Hydraulic Oil	

*Crimper capacity is estimated based on typical 1-piece fitting. Actual results may vary depending on the fitting and hose manufacturer.



CUSTOM CRIMP™

Innovating SMART Hose Assembly Solutions Since 1979

D105/D165 D-SERIES DRAWER ASSEMBLY / STAND

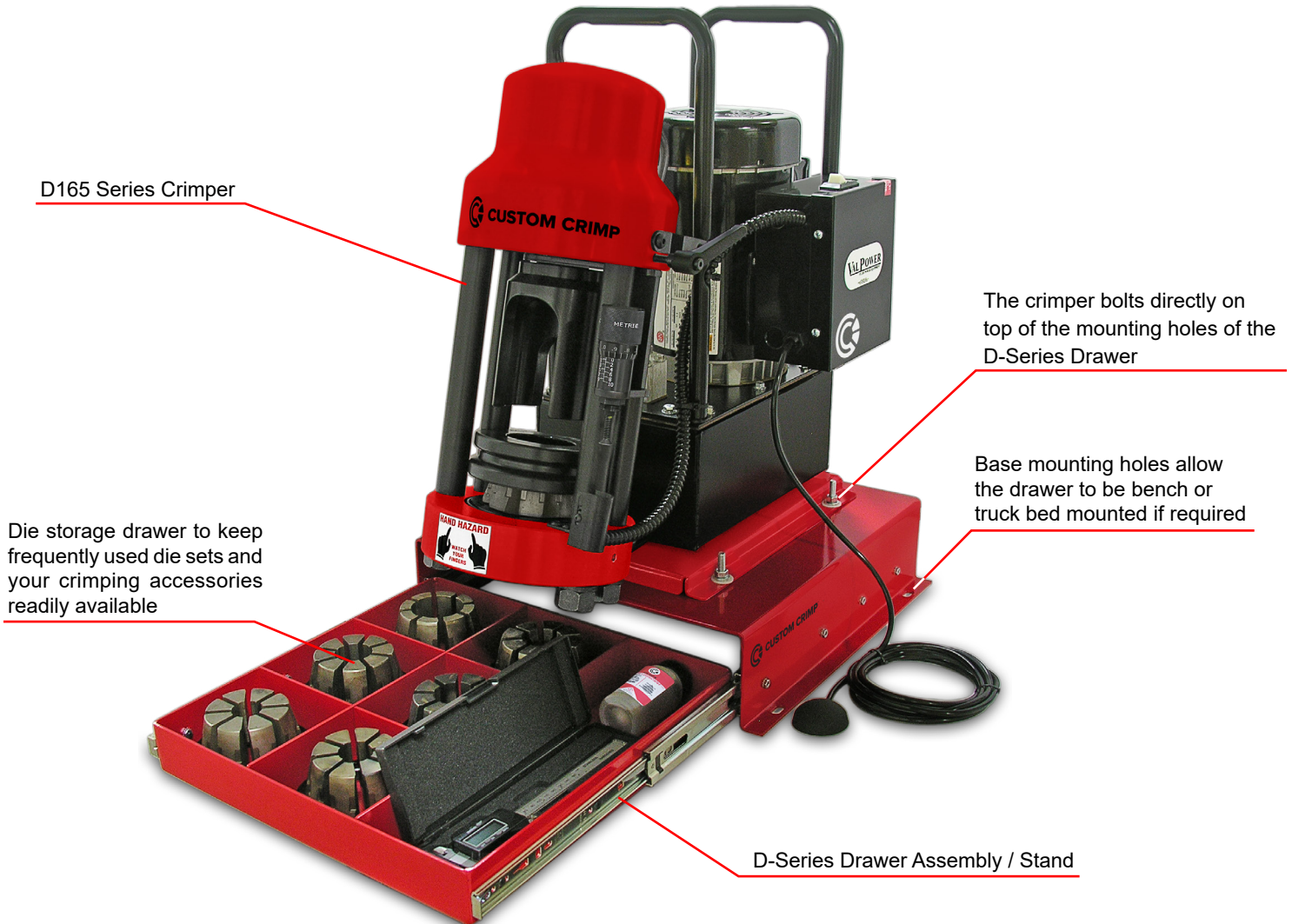

D-Series Drawer Assembly / Stand is available for D105 / D165 Series Crimpers.



CUSTOM CRIMP™

Innovating SMART Hose Assembly Solutions Since 1979

FEATURES



Metric Micrometer “Micro-Crimp Adjuster” is fully adjustable to make precise and repeatable crimps.



Open design, two piece “slide in” die set and removable pusher allows the operator to accurately position the fitting prior to crimping.



Built-in adjustable retraction stop limits ram retraction for quick repetitive crimps.



An easily removable Coupling Stop makes repetitive crimps faster by not having to visually align the fitting before each crimp.



Automatic stop switch shuts the pump off when the crimp cycle is complete.



Easy calibration adjustment to increase or decrease crimp OD.



CUSTOM CRIMP™

Innovating SMART Hose Assembly Solutions Since 1979

INITIAL SET UP

FOLLOW THESE STEPS BEFORE YOU USE THE CRIMPER FOR THE FIRST TIME.

- Mount the crimper on a sturdy workbench in a well-lit area. Workbench should be able to support the crimper and components weight.

Note: The D165 series can be mounted on the D-Series Drawer/Stand and bolted onto the workbench. (See detailed instructions included with D165 drawer/stand).

- The crimper should be mounted close enough to the edge of the work surface so that hose will not contact the bench or work surface while crimping. There must be enough clearance for the hose to align perpendicular with the cone base, or the dies will not seat properly and the crimps will not be accurate.

- Always check oil level in the D165 pump, should be 1-1/2 to 2 inches below the vent plug when the cylinder is in the retracted position and should be visible in the sight glass window of the pump reservoir.

- If oil needs to be added use ISO 46 weight hydraulic oil.

- Oil can be drained from the rear oil port of the reservoir.

- Check to be certain that the shipping plug in the pump reservoir has been replaced with the vent plug shipped with the D165 crimper.





CUSTOM CRIMP™

Innovating **SMART** Hose Assembly Solutions Since 1979

INITIAL SET UP

- Check electrical circuit to be certain that it matches the crimper requirements shown on the voltage tag attached to the crimper cord.
- Plug the D165 crimper directly into a 110 volt, 15 amp wall outlet.

Note: The optional 220 volts / 2HP unit must be connected to a 220 volts 20 amp wall outlet.



- ValPower® offers rugged industrial duty hydraulic power units that will meet the demanding requirements of industrial users.



CUSTOM CRIMP™

Innovating SMART Hose Assembly Solutions Since 1979

LUBRICATION PROCEDURE



Grease Point # 1

Insert the pressure plate into the bottom flange of the crimper, making sure that it is seated squarely into the bottom flange.

Place a thin layer of CrimpX oil (supplied with crimper) or a high pressure molybdenum high pressure grease on the surface the dies sit on (as shown in photo # 1).



Photo # 1

Grease Point # 2

Before sliding the standard compression ring or the notched compression ring over the correct dies, place a thin layer of CrimpX oil (supplied with crimper) or a high pressure molybdenum high pressure grease on the entire area that dies come in contact with on the inner diameter (as shown in photo # 2).



Photo # 2

If Breaking Die Screws Often: Continue to lubricate / grease as explained above in addition to lubricating each die finger individually (as shown in photo # 3A).

If Compression Ring Sticks: The die fingers must be lubricated on each segment that comes in contact with the compression ring (as shown in photo # 3B).

Note: Lubrication is not required before each crimp.
Typical lubrication is after 100 crimps.

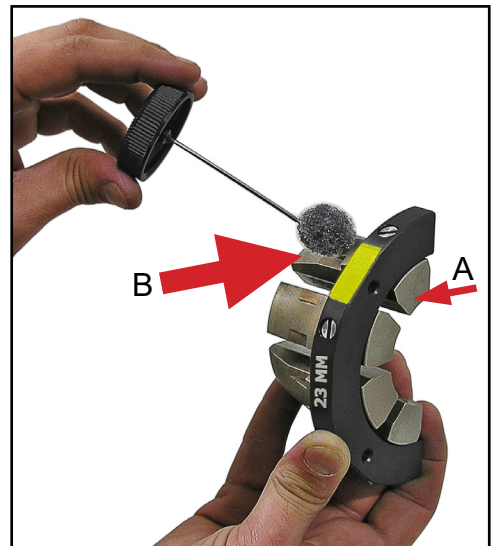

Photo # 3



CUSTOM CRIMP™

Innovating SMART Hose Assembly Solutions Since 1979

CRIMPING WITH STANDARD COMPRESSION RING

Note: Follow the lubrication procedure prior to crimping procedure.

NOTE: FAILURE TO LUBRICATE THE DIE SET AND COMPRESSION RING COULD RESULT IN THE DIE SET SEIZING IN THE BASE FLANGE.

Step 1: Insert the pressure plate into the bottom flange of the crimper, making sure that it is seated squarely into the bottom flange.

Note: Make sure the **Pressure Plate** is lubricated prior to inserting the die set.

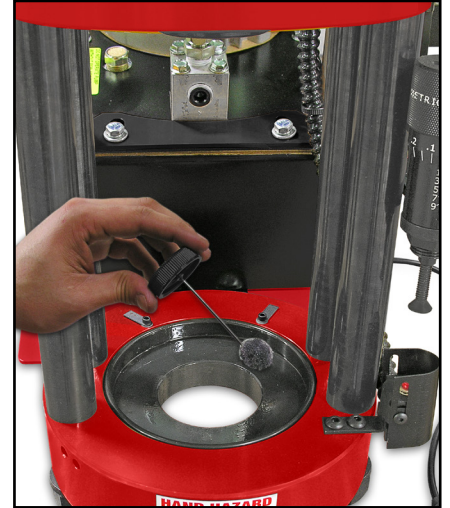

Step 2: Select the correct die set for the combination of hose and fitting being crimped.

Note: Consult your hose and fitting manufacturer for the correct die size for the combination of hose and fitting being crimped.

Note: The number etched on the OD of the die ring represents the fully closed diameter of the die set in millimeters. In addition, die sets are color-coded for easier identification.



Step 3: Lubricate the contact surfaces, both bottom and outside edges of the die fingers, with CrimpX oil (supplied with crimper) or a high pressure molybdenum high pressure grease.

Failure to lubricate the contact surfaces with the correct lubricant will cause the dies to seize in the compression ring, causing damage to the die set as well as possibly damaging the crimper.

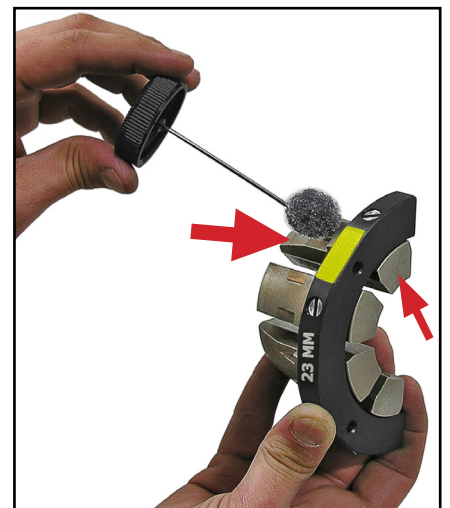



CUSTOM CRIMP™

Innovating SMART Hose Assembly Solutions Since 1979

CRIMPING WITH STANDARD COMPRESSION RING

Step 4: Place the **Lubricated Die Set** squarely in the pressure plate.



Step 5: Align the **Fitting** in the die set according to the hose and fitting manufacturer's recommendation.

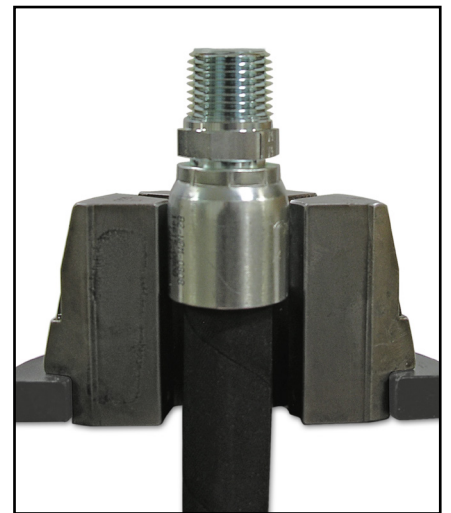

Step 6: Place the **Lubricated Compression Ring** over the die set and compress the die set by hand to hold the hose and fitting in place.





CRIMPING WITH STANDARD COMPRESSION RING

Note: Make sure the compression ring is seated evenly on the die set.



CAUTION: The notches on the die set must be completely covered by the compression ring prior to starting the crimp.

- If the notches are showing, you must go to a larger die set.
- Crimping with an incorrect die size could result in personal injury.



CUSTOM CRIMP™

Innovating SMART Hose Assembly Solutions Since 1979

CRIMPING WITH STANDARD COMPRESSION RING

Step 7: Slide the **Pusher** onto the pusher retaining ring on the hydraulic cylinder.

Note: Make sure slot in pusher goes over lip on pusher retaining ring.

CAUTION: Damage to pusher and retaining ring can occur if misaligned.

Front View

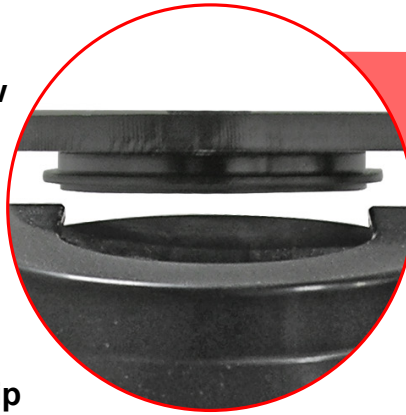

Rear View

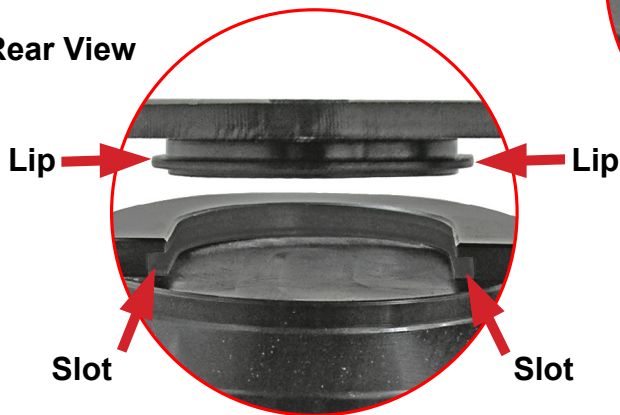

Pusher Retaining Ring

Note: Make sure the pusher is positioned correctly as shown.





CUSTOM CRIMP™

Innovating SMART Hose Assembly Solutions Since 1979

CRIMPING WITH STANDARD COMPRESSION RING

Step 8: Set the **Micro-Crimp Adjuster** to the setting recommended by the hose and fitting manufacturer for the combination of hose and fitting being crimped.

NOTE: The Metric Micro-Crimp Adjuster is a direct reading micrometer. Add the setting on the micrometer to the closed diameter of the die set to obtain the finished crimp diameter.

For example: With a 23mm die set and the Micro-Crimp Adjuster set at 3.0, the finished crimp diameter would be 26.0 mm (23mm + 3.0mm).

Note: Each die set has a limited range of diameters for which a satisfactory crimp can be obtained. Always consult your hose and fitting manufacturer for the correct die set for the hose and fitting being crimped.

Step 9: Recheck the fitting for the correct alignment in the die set and depress the start/stop switch.

Depress and hold the Start/Stop switch, until the micrometer touched the electronic red button as shown, “count one mississippi” the automatic stop switch will shut the pump off, and the ram will return to the retracted position. Allow the pusher to return to the retracted position as well.

Step 10: Check the final crimp diameter with calipers to confirm that it is within manufacturer’s specifications.

Note: Always consult with your hose and fitting manufacturer to obtain the most current crimp specifications.





CUSTOM CRIMP™

Innovating SMART Hose Assembly Solutions Since 1979

CRIMPING WITH **NOTCHED** COMPRESSION RING

WHEN USING THE NOTCHED COMPRESSION RING,
FOR USE WITH 90 DEGREE FITTING ONLY,
FOLLOW THESE PROCEDURES:

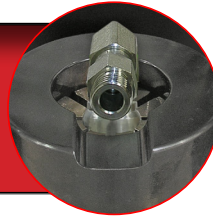

Note: Follow the lubrication procedure prior to crimping procedure.

CAUTION: Failure to lubricate the die set and notched compression ring could result in the die seizing in the base flange.

Step 1: Insert the **Pressure Plate** into the bottom flange of the crimper, making sure that it is seated squarely into the bottom flange.

Note: Make sure the **Pressure Plate** is lubricated prior to inserting the die set.

Step 2: Place the **Lubricated Die Set** squarely in the pressure plate for the combination of hose and fitting being crimped.

Note: Consult your hose and fitting manufacturer for the correct die size for the combination of hose and fitting being crimped.

Note: The number etched on the OD of the die ring represents the fully closed diameter of the die set in millimeters. In addition, die sets are color-coded for easier identification.

Step 3: Place the **Lubricated Notched Compression Ring** loosely but evenly over the die set. Make sure die set is correctly aligned.





CUSTOM CRIMP™

Innovating SMART Hose Assembly Solutions Since 1979

CRIMPING WITH NOTCHED COMPRESSION RING

Step 7: CAUTION: DO NOT MISALIGN NOTCHED COMPRESSION RING OR DAMAGE WILL OCCUR.

Note: When crimping with the notched compression ring the “Notched” **MUST** face forward or damage can occur to die fingers if parts aren’t aligned properly.



Step 6: After placing the notched compression ring facing forward, align the hose assembly with **90 degree fitting** in the die set according to the hose and fitting manufacturer’s recommendation.

Note: Manually depress the notched compression ring, closing the die set until the hose and 90 degree fitting are held loosely in the die set. Seat the notched compression ring evenly on the die set.



CAUTION: The notches on the die set must be completely covered by the compression ring prior to starting the crimp.

- If the notches are showing, you must go to a larger die set.
- Crimping with an incorrect die size could result in personal injury.



CRIMPING WITH NOTCHED COMPRESSION RING

Step 8: Slide the **Pusher** onto the pusher retaining ring on the hydraulic cylinder.

Note: Make sure slot in pusher goes over lip on pusher retaining ring. Refer to page 13 for details if needed.

CAUTION: Damage to pusher and retaining ring can occur if misaligned.

Step 8: Set the **Micro-Crimp Adjuster** to the setting recommended by the hose and fitting manufacturer for the combination of hose and fitting being crimped.

NOTE: The Metric Micro-Crimp Adjuster is a direct reading micrometer. Add the setting on the micrometer to the closed diameter of the die set to obtain the finished crimp diameter.

For example: With a 23mm die set and the Micro-Crimp Adjuster set at 3.0, the finished crimp diameter would be 26.0 mm (23mm + 3.0mm).

Note: Each die set has a limited range of diameters for which a satisfactory crimp can be obtained. Always consult your hose and fitting manufacturer for the correct die set for the hose and fitting being crimped.

Step 9: Recheck the fitting for the correct alignment in the die set and depress the start/stop switch.

Depress and hold the Start/Stop switch, until the micrometer touched the electronic red button as shown, “count one mississippi” the automatic stop switch will shut the pump off, and the ram will return to the retracted position. Allow the pusher to return to the retracted position as well.





CUSTOM CRIMP™

Innovating SMART Hose Assembly Solutions Since 1979

CRIMPING WITH NOTCHED COMPRESSION RING

Step 10: Check the final crimp diameter with calipers to confirm that it is within manufacturer's specifications.

Note: Always consult with your hose and fitting manufacturer to obtain the most current crimp specifications.

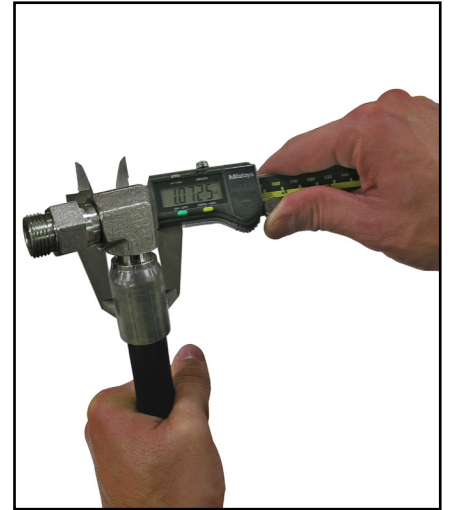



CUSTOM CRIMP™

Innovating SMART Hose Assembly Solutions Since 1979

CALIBRATION CHECK PROCEDURE

THE CRIMPER IS CALIBRATED PRIOR TO SHIPMENT, BUT A CALIBRATION CHECK IS RECOMMENDED PRIOR TO USING THE CRIMPER FOR THE FIRST TIME.

Note: Follow the lubrication procedure prior to calibration check.

NOTE: FAILURE TO LUBRICATE THE DIE SET AND COMPRESSION RING COULD RESULT IN THE DIE SET SEIZING IN THE BASE FLANGE.

Step 1: Place the **Lubricated Pressure Plate**, into the bottom flange of the crimper, making sure that it is seated squarely into the bottom flange.



Step 2: Place **Any Lubricated Die Set** squarely in the pressure plate.



Step 3: Place the **Lubricated Compression Ring** over the die set.

Note: Make sure the compression ring is seated evenly on the die set.

Note: A hose and fitting are not required for a calibration check.





CUSTOM CRIMP™

Innovating SMART Hose Assembly Solutions Since 1979

CALIBRATION CHECK PROCEDURE

Step 4: Slide the **Pusher** onto the pusher retaining ring on the hydraulic cylinder.

Note: Make sure slot in pusher goes over lip on pusher retaining ring. Refer to page 13 for details if needed.

CAUTION: Damage to pusher and retaining ring can occur if misaligned.



Step 5: Set the **Metric Micro-Crimp Adjuster** at “0”.

Note: Set the Micro-Crimp Adjuster at “100” for the Standard Micrometer. Set the Micro-Crimp Adjuster at “95” for the DC Micrometer.



Step 6: Depress and hold the Start/Stop switch, until the Die set is completely closed and oil pressure has built up in the hydraulic cylinder.

If the ram extends, the dies are completely closed, the pump builds pressure (The sound of the pump will change) when the micrometer touched the electronic red button as shown, “count one mississippi” the automatic stop switch will shut the pump off, and the ram will return to the retracted position the crimper is correctly calibrated.





CALIBRATION CHECK PROCEDURE

Step 7: If the above conditions are not met, the crimper requires recalibration, hold the micrometer barrel with a 5/16 inch open end wrench and rotate the stem either in or out with a 5/32 inch hex key wrench.

Note: 1/4 turn of screw will change crimp diameter approximately 0.008".

- Rotating the stem out of the barrel decreases the time required for the pump to shut off.
- Recheck calibration.





CUSTOM CRIMP™

Innovating SMART Hose Assembly Solutions Since 1979

D105/D165 D-SERIES DRAWER ASSEMBLY / STAND



1

Install (2) 3/8-16 x 1" carriage bolts in front two holes (as shown in picture # 1). Use 3/8" plastic retaining washer to hold bolt into place.



2

Slide the drawer slightly out to access two rear holes (as shown in picture # 2). Install (2) 3/8-16 x 1" carriage bolts in rear two holes (as shown in picture # 2). Use 3/8" plastic retaining washer to hold bolt into place.



3

Place the D105/D165 base plate over the 4 screws as shown in picture # 3. Place 3/8" flat washer, 3/8" locking washer, and then the 3/8"- 16 nut over the bolt as shown.



4

Tighten each nut with a 9/16" wrench or socket until the nuts are tight as shown in picture # 4.

Note: Bolt the D105/D165 crimper drawer assembly / stand to work surface before use.



CUSTOM CRIMP™

Innovating SMART Hose Assembly Solutions Since 1979

INCLUDED ACCESSORIES

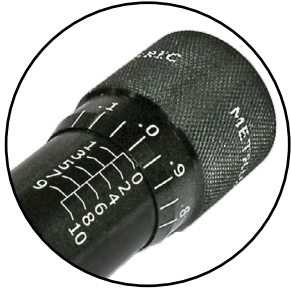

Metric Micrometer
P/N:101587



Pusher w/ Magnets
P/N:100825-01



Compression Ring
P/N:102213



Pressure Plate
P/N:102211



Pneumatic Pendant Switch
P/N:101349



D165 Coupling Stop
P/N:100954



CRIMPX Die Lubricant Oil:
4 oz bottle with dauber cap
P/N:103886



Vent Plug
P/N:9847K13



(5) D100 Screws
P/N:EN84-115 (Sold individually)



(5) D100 Spring
P/N:LC 022D 01 (Sold individually)



CUSTOM CRIMP™

Innovating SMART Hose Assembly Solutions Since 1979

AVAILABLE ACCESSORIES



Standard Micrometer
P/N:100628

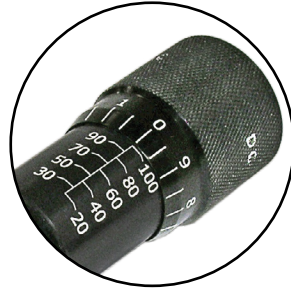

DC Micrometer
P/N:101489



Notched Compression Ring
(Ideal for 90 deg. Fittings)
P/N:103072



Flexible 24" Work Lamp
P/N:1668-02



Die Storage Shelf
P/N:101431

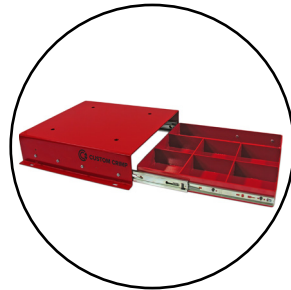

D-Series Drawer
Assembly/Stand
P/N:104650



Die Removal Magnet
P/N:104679



CRIMPX Die Lubricant:
Grease 4 oz can with brush
P/N:104162



CustomCrimp® Notched Digital
Caliper IN/MM P/N:CC-Caliper



TROUBLESHOOTING

PROBLEM: CRIMPER WILL NOT RUN AT ALL

- The white rocker switch is also a circuit breaker. Check to see that the circuit breaker has not been tripped.
- Check the wall outlet. The crimper comes from the factory wired for a 115 volt single phase circuit. Use of extension cords or outlets with inadequate power can damage the motor. Do not run the crimper from a portable power source.
- Check the stop switch mounted to the switch bracket under the Micro-Crimp Adjuster. This is a normally closed switch and if it does not close the crimper will not operate.
CAUTION: Do not operate the crimper with this switch jumpered as the pump will not shut off and the brackets can be damaged.
- Check the pneumatically actuated switch in the electrical box mounted on the motor. This switch controls power to the motor and is actuated with air pressure from the pendant switch bulb.

PROBLEM: CRIMP DIAMETER TOO LARGE

- Incorrect setting of the Micro-Crimp Adjuster. Check crimp specifications.
(NOTE: All published machine settings are approximate. To correct for slight variances, the gauge settings may need to be adjusted for the specific hose, fitting and size combination).
- Incorrect die being used. Each die has a useable range of approximately 3mm (.120 in) above the closed diameter of the die. The closed diameter is the die size stamped on the die ring.
- Check crimper calibration and re-calibrate if required.
- Inadequate pump pressure. Check oil level in the pump. It should be 1-1/2 to 2 inches below the fill plug.
- Replenish with ISO Viscosity Grade 46 hydraulic oil.
- Inadequate lubrication of the dies and compression ring causing the pump to work harder than normal to reach the required diameter. Use only the crimpx oil / grease shipped with the machine or a high pressure molybdenum high pressure grease (equivalent).
- Inadequate pressure being generated by the pump. This is most likely if the crimper can crimp the smaller size hoses and not the larger hoses. When correctly adjusted, the pump should generate approximately 10,000 psi.
Do Not adjust pump to produce in excess of 10,000 psi as damage to components or personal injury may result.
- No pressure being generated by the pump. There should be a definite change in pitch of the pump as it cycles into high pressure mode and begins to “work” harder.

PROBLEM: CRIMP DIAMETER TOO SMALL

- Incorrect setting of the Micro-Crimp Adjuster. Check crimp specifications.
(NOTE: All published machine settings are approximate. To correct for slight variances, the gauge settings may be adjusted for the specific hose, fitting and size combination).
- Incorrect die being used (See die range under Crimp Diameter Too Large).
- Check crimp diameter and re-calibrate if necessary.

PROBLEM: DIES STICKING IN COMPRESSION RING

- Inadequate lubrication of the compression ring and die surfaces. Use only the crimpx oil / grease shipped with the machine or a high pressure molybdenum high pressure grease (equivalent).
- Refer to D165 Lubrication Procedure for more details.



COMPONENT PARTS BREAKDOWN

D100 SERIES DIE PARTS (AI-100724)			
ITEM	PART NUMBER	DESCRIPTION	QTY
1	101065-COLOR	DIE RING HALF D100 SERIES	2
2	VARIES WITH THE DIE SIZE	8 PC DIE FINGER SET	8
3	EN84-115	D100 SCREW	8
4	LC 022D 01	D100 SPRING	8

DIE RING HALF D100 SERIES	
PART NUMBER	DESCRIPTION
101065-BLACK	DIE RING HALF BLACK
101065-BLUE	DIE RING HALF BLUE
101065-BROWN	DIE RING HALF BROWN
101065-GREEN	DIE RING HALF GREEN
101065-ORANGE	DIE RING HALF ORANGE
101065-PURPLE	DIE RING HALF PURPLE
101065-RED	DIE RING HALF RED
101035-SILVER	DIE RING HALF SILVER
101065-YELLOW	DIE RING HALF YELLOW

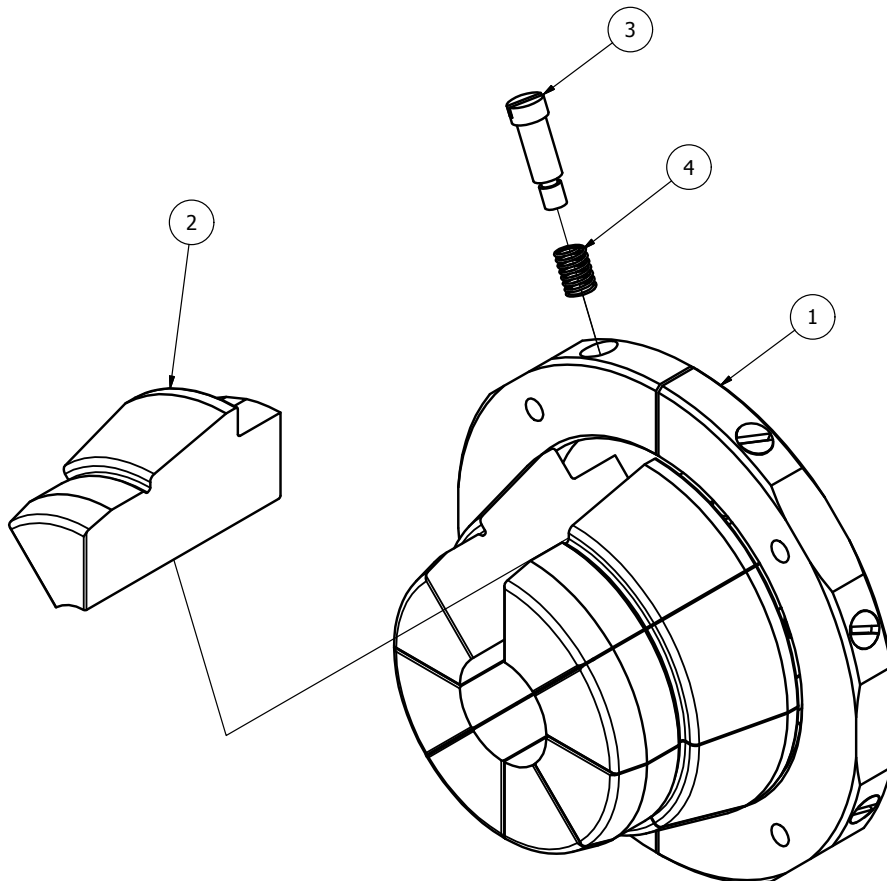



COMPONENT PARTS BREAKDOWN

60 Ton Cylinder / Top Flange Assembly (102219)			
Item	Part Number	Description	Qty
1	102158	60 Ton Body / Top Flange	1
2	100651	60 Ton Piston	1
3	227-9250	227 Disogrin O-Ring	1
4	101106	Piston End Cap	1
6	100760_12	60 Ton Spring	1
7	102287	Spring Plug	1
8	210D90	210 Disogrin O-Ring	1
9	F1-POM-3.75X4.00X0.375	3.75 x 4.00 x 0.375 Wear Ring	2
10	POLYPAK 4 x 3-1/2 x 3/8	3.50 x 4.00 x 0.375 Polypak	1
11	90108A417	3/8 Flat Washer	1
12	91251A632	3/8-16 x 2 SHCS	1
13	SH940-35	375 Ram Wiper	1
14	102169	60 Ton Retaining Ring	1
15	91251A424	3/8-24 X 1" SHCS	6

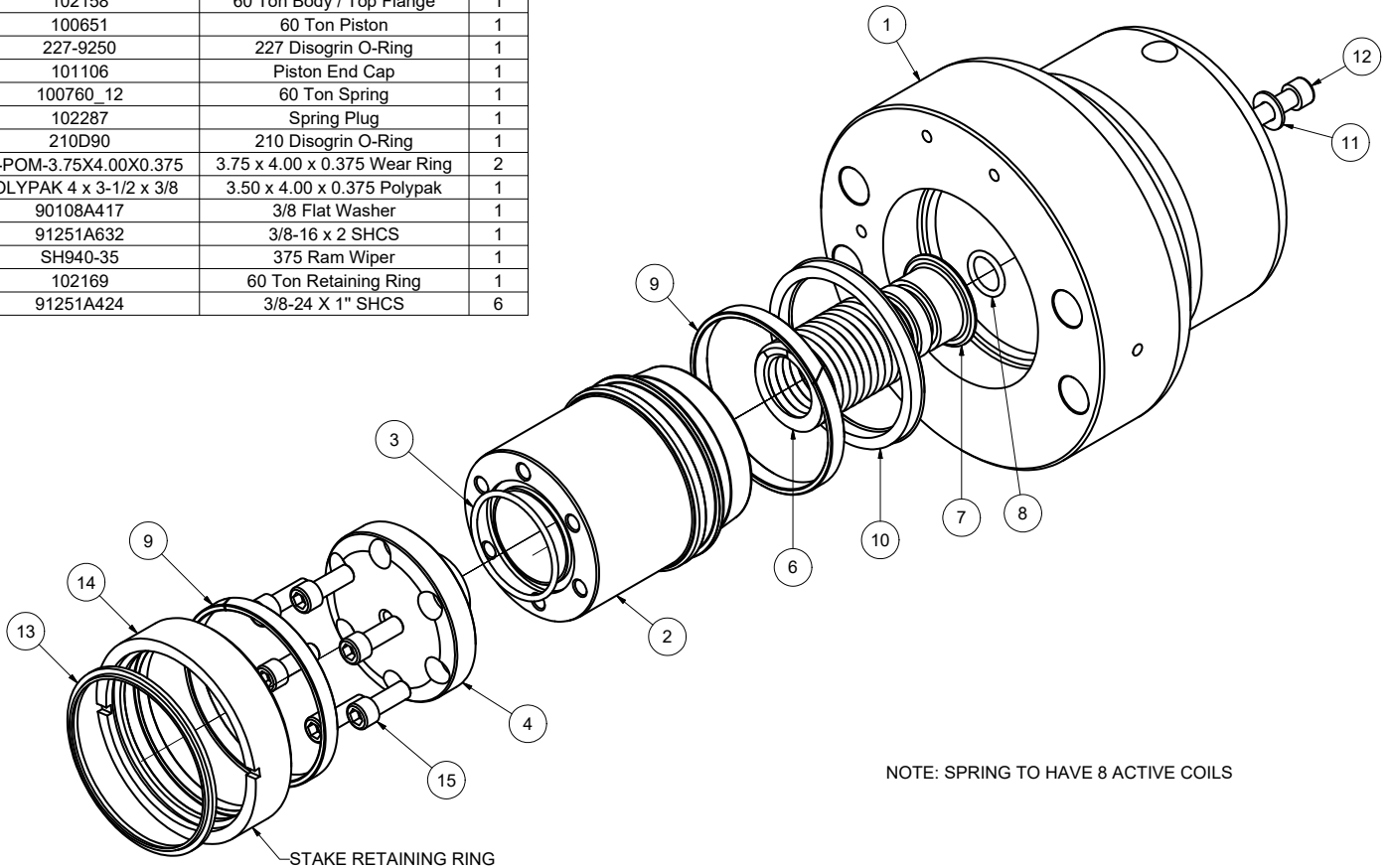



CUSTOM CRIMP™

Innovating SMART Hose Assembly Solutions Since 1979

COMPONENT PARTS BREAKDOWN

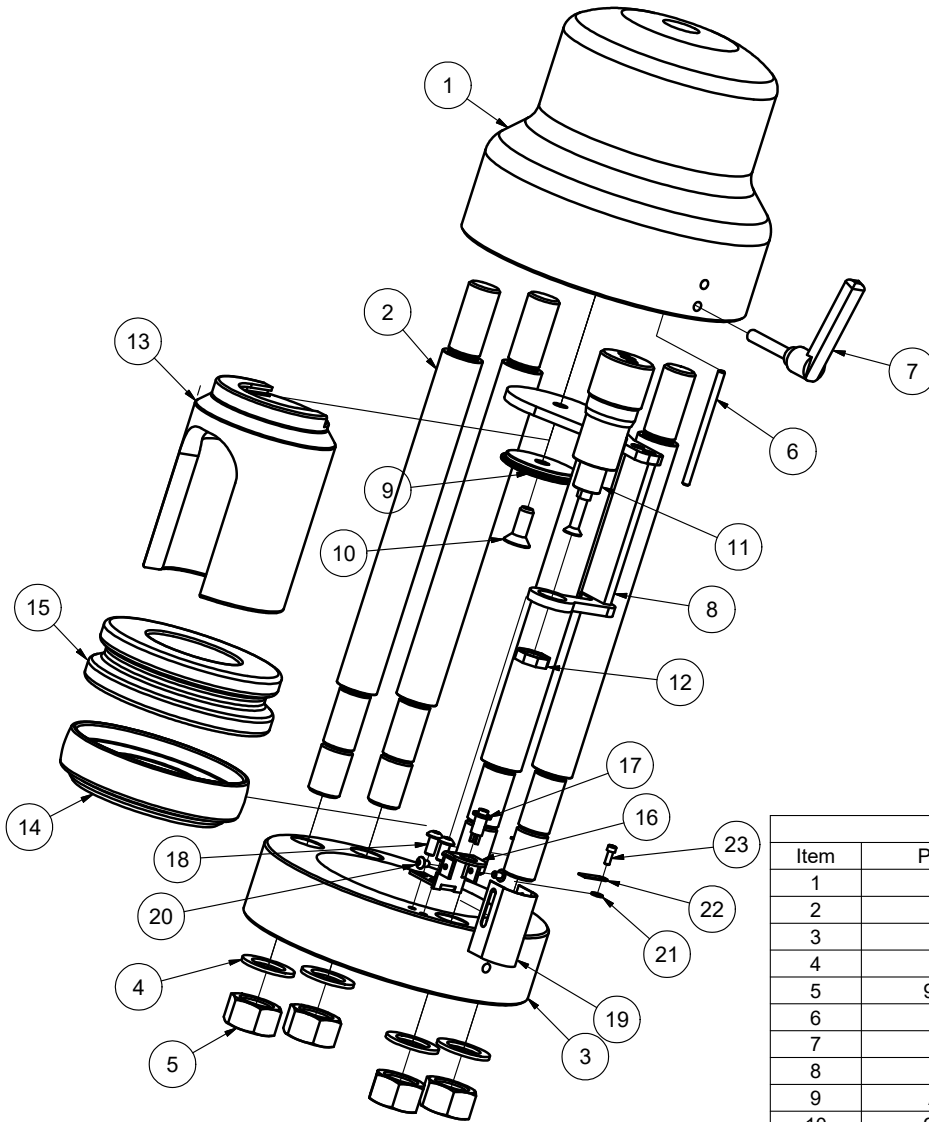

D165 Crimper Head Assembly (102161)			
Item	Part Number	Description	Qty
1	102219	60 Ton Cylinder / Top Flange	1
2	102212	Strain Rod	4
3	102159	Bottom Flange	1
4	11038	7/8 Narrow Rim Washer	4
5	90499A845	7/8 - 14 Hex Nut	4
6	102224	Retraction Stop Rod	1
7	KHA-126	Stop Rod Locking Handle	1
8	102220	Micrometer Mount Assembly	1
9	AI-100812	Pusher Retaining Disc	1
10	91253A624	3/8-16 x 1 HSFHCS	1
11	100628	Standard Micrometer Assembly	1
11	101489	DC Micrometer Assembly	1
11	101587	Metric Micrometer Assembly	1
12	100727	Micrometer Nut	1
13	100825	Pusher Less Magnets	1
13	100825-01	Pusher With Magnets	1
14	102211	Pressure Plate	1
15	102213	Compression Cone	1
16	101092	Limit Switch Bracket	1
17	903 Switch	Limit Switch	1
18	91255A537	1/4-20 x 1/2 BHCS	2
19	100692	Limit Switch Guard	1
20	91255A190	8-32 x 1/4 BHCS	2
21	95630A237	#6 Teflon Washer	2
22	102218	Die Retaining Clip	2
23	91251A146	6-32 x 3/8 SHCS	2



COMPONENT PARTS BREAKDOWN

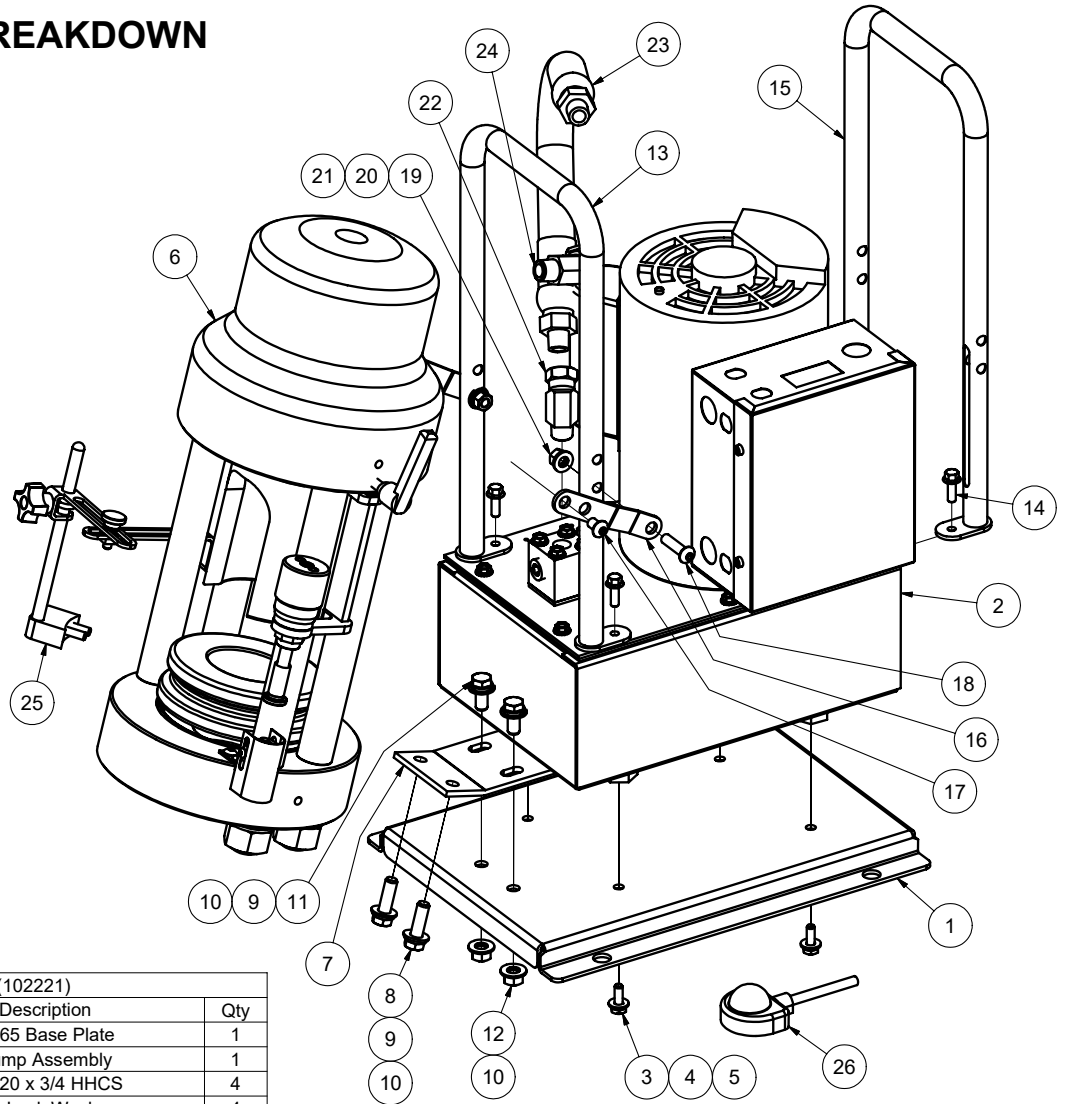

D165 Crimper Assembly (102221)			
Item	Part Number	Description	Qty
1	101430	D165 Base Plate	1
2	101633	Pump Assembly	1
3	92865A540	1/4-20 x 3/4 HHCS	4
4	91102A029	1/4 Lock Washer	4
5	90126A029	1/4 Flat Washer	4
6	102161	D165 Crimper Head Assembly	1
7	101429	Crimper Head Mounting Bracket	1
8	92865A626	3/8-16 x 1 1/4 HHCS	2
9	91102A031	3/8 Lock Washer	4
10	90126A031	3/8 Flat Washer	6
11	92865A623	3/8-16 x 7/8 HHCS	2
12	95462A031	3/8-16 Hex Nut	2
13	102160	Front Handle Assembly	1
14	92323A516	1/4-20 x 3/4 HHFCS	4
15	102222	Rear Handle Assembly	1
16	102052	Crimper Head Brace	2
17	91255A578	5/16-18 x 1/2 BHCS	2
18	91255A585	5/16-18 x 1 1/4 BHCS	2
19	95462A030	5/16-18 Hex Nut	2
20	91102A030	5/16 Lock Washer	2
21	90126A030	5/16 Flat Washer	2
22	60TA-06X08	45 Deg Swivel Fitting	1
23	102225	D165 High Pressure 1/2" Hose	1
24	60TA-08X08	45 Deg Swivel Fitting	1
25	100954	Coupling Stop Assembly	1
26	101349	Pneumatic Pendant Switch	1



COMPONENT PARTS BREAKDOWN

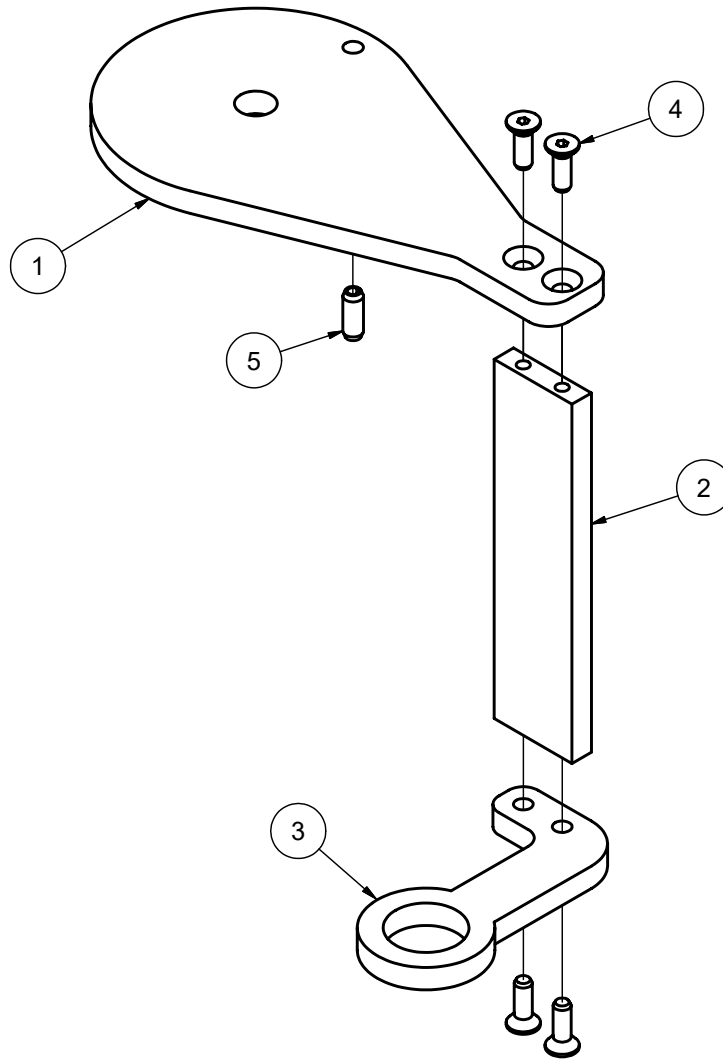

D165 Micrometer Mount Assembly (102220)			
Item	Part Number	Description	Qty
1	102214	Micrometer Suspension Flange	1
2	102217	Micrometer Brace	1
3	102215	Micrometer Base Bracket	1
4	91253A194	8-32 x 1/2 HSFHCS	4
5	98296A245	3/16 Dia. x 1/2 Spring Pin	1



CUSTOM CRIMP™

Innovating SMART Hose Assembly Solutions Since 1979

CUSTOMCRIMP® “NO-NONSENSE” WARRANTY STATEMENT

All Custom Crimp® Products are warranted to be free of defects in workmanship and materials for one year from the date of installation. This warranty ends when the product becomes unusable for reasons other than defects in workmanship or material.

Any Custom Crimp® Product proven to be defective in workmanship or material will be repaired or replaced at no charge. To obtain benefits of this warranty, first, contact Warranty Repair Department at Custom Machining Services at **(219) 462-6128** and then deliver via prepaid transportation the complete hydraulic product to:

**ATTN: WARRANTY REPAIR DEPT.
Custom Machining Services, Inc.
318 North Co. Rd 400 East
Valparaiso IN 46383**

If any product or part manufactured by Custom Crimp® is found to be defective by Custom Crimp®, at its option, Custom Crimp® will either repair or replace the defective part or product and return via ground transportation, freight prepaid.

Custom Crimp® will not cover any incoming or outgoing freight charges for machines sold outside The United States.

This warranty does not cover any product or part which is worn out, abused, altered, used for a purpose other than for which it was intended, or used in a manner which was inconsistent with any instructions regarding its use.

Electric motors are separately warranted by their manufacturer under the conditions stated in their separate warranty.

CRIMP

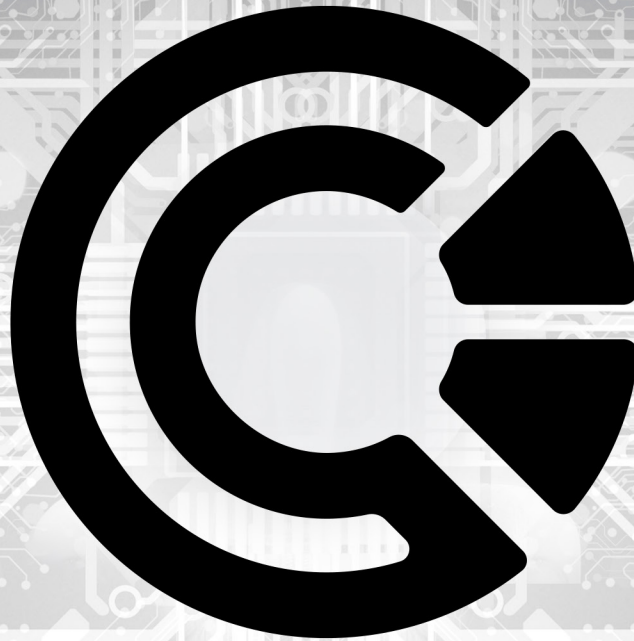

CUT

TEST

CUSTOM CRIMP®, YOUR SINGLE SOURCE FOR HOSE ASSEMBLY PRODUCTS.

CUSTOM CRIMP® | Custom Machining Services, Inc.
326 North 400 East Valparaiso, IN 46383



Visit us at: www.customcrimp.com



For sales: ccsales@customcrimp.us



For support: ccsupport@customcrimp.us



Custom Crimp®

Innovating **SMART** Hose Assembly Solutions Since 1979

www.customcrimp.com

(219) 462-6128