



CUSTOM CRIMP™

Innovating SMART Hose Assembly Solutions Since 1979



CC15 HYDRAULIC CRIMPER OPERATORS MANUAL



CUSTOM CRIMP™

Innovating **SMART** Hose Assembly Solutions Since 1979



SAFETY PRECAUTIONS



- READ INSTRUCTIONS AND IDENTIFY ALL COMPONENT PARTS BEFORE USING CRIMPER.
- CRIMPER CC15 CAN PRODUCE 33 TONS OF CRIMPING FORCE.
- KEEP BOTH HANDS AWAY FROM PINCH POINTS.
- CONSULT HOSE AND FITTING MANUFACTURER FOR CORRECT MACHINE SETTINGS AND CRIMP MEASUREMENTS.
- ALWAYS WEAR EYE PROTECTION.



CUSTOM CRIMP™

Innovating **SMART** Hose Assembly Solutions Since 1979

TABLE OF CONTENT

SAFETY PRECAUTIONS-----	2
COMPONENT PARTS & TECHNICAL DATA-----	4
INITIAL SET UP & MAINTENANCE-----	5
CRIMPING PROCEDURE-----	6
CALIBRATION PROCEDURE-----	7
TROUBLESHOOTING-----	8
CC15 CRIMPER REPLACEMENT ACCESSORIES-----	9
COMPONENT PARTS BREAKDOWN-----	10
CUSTOM CRIMP® “NO-NONSENSE” WARRANTY STATEMENT-----	11
CUSTOM CRIMP® CONTACT INFORMATION-----	12



CUSTOM CRIMP™

Innovating SMART Hose Assembly Solutions Since 1979

COMPONENT PARTS & TECHNICAL DATA

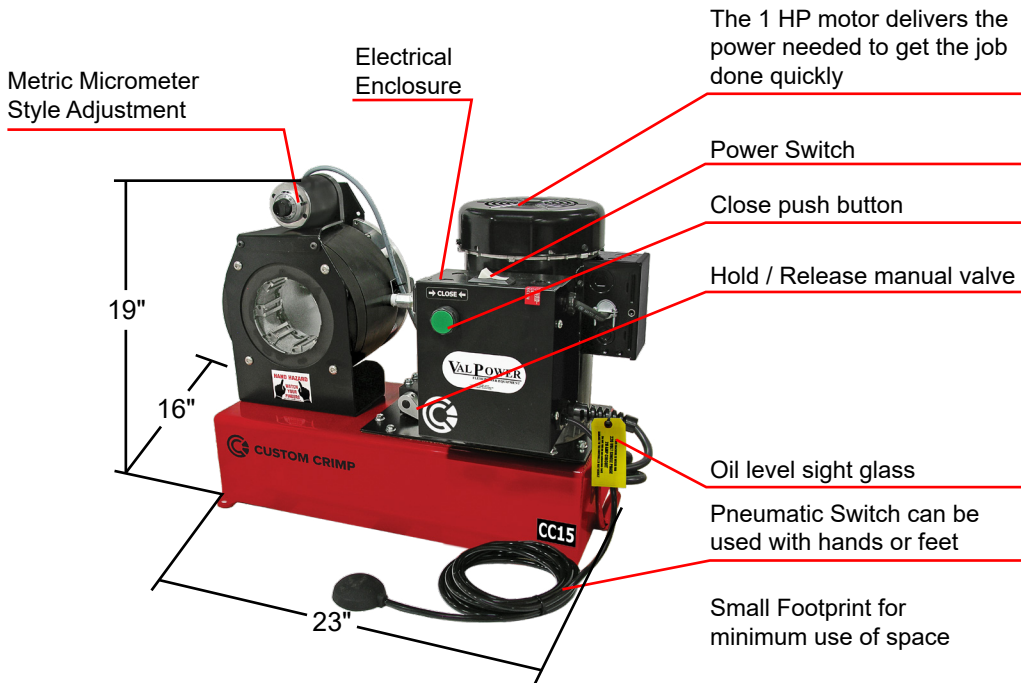

CC15 Technical Specifications

Crimping Force: 33 Ton
Hydraulic Hose Capacity: 5/8" 2 Wire 1/2" 4SP
Crimper Size: L: 16" x W: 23" x H: 19"
Crimper Weight: 150 lbs
Power: 1HP / 110V / 1Phase (Standard) 2HP / 220V / 1Phase (Optional) 1HP / 12V / 1Phase (Optional) 1HP / 24V / 1Phase (Optional)
Die series: K16
Adjustability: Manual / Metric
Opening w/o dies: 94mm / 3.7"
Master die travel: 27.5mm / 1.1"
Reservoir capacity: 13 Quarts
Oil type: ISO 46 Hydraulic Oil

Retraction Stop:

- When making repetitive crimps, setting the Retraction Stop at a point where the hose and fitting can be conveniently withdrawn without allowing the cylinder to fully retract will greatly reduce the crimp cycle times.

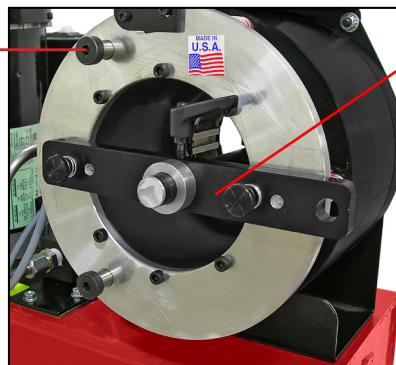

Back Stop:

- When making repetitive crimps, setting the Coupling Stop eliminates the need to visually align the couplings each time.

For repetitive crimps, position the hose and fitting in the correct position and bring the face of the coupling stop against the fitting. Tighten the coupling stop in the correct position.



CUSTOM CRIMP™

Innovating SMART Hose Assembly Solutions Since 1979

INITIAL SET UP & MAINTENANCE

Do not lift the machine by the crimper head.
Lift with a fork lift under the tank.

Mount the crimper on a sturdy surface.

Check electrical circuit to be certain that it matches the crimper requirements shown on the tag attached to the crimper cord.

Electrical Requirements:

- 1HP / 110V / 1Phase (Standard)
- 2HP / 220V / 1Phase (Optional)
- 1HP / 12V / 1Phase (Optional)
- 1HP / 24V / 1Phase (Optional)

Check the oil level in the sight glass on the side of the crimper.
13 quarts of ISO 46 hydraulic oil are required to completely refill the tank.

Oil can be drained from either port on the side of the tank.

LUBRICATION:

- Check the tank sight glass for proper reservoir oil level. If additional oil is required fill with ISO Grade 46 hydraulic oil.

Crimper Head Lubrication

Lubrication passages are drilled in the CC15 die holders. This feature makes positive lubrication of the wear surfaces much easier assuring longer life and smoother crimper operation. Foam pads are installed between the die holders to keep dirt and debris from destroying the die and piston surfaces.

- Close the die holders to a position nearly flush with the front plate of the crimper to expose the lubrication fittings in the front of the die holders. Lubricate with the CrimpX grease furnished with the crimper or a moly-disulfide lubricant. Failure to use a high quality lubricant can result in premature wear and possible damage to the master dies and piston surfaces.

- The foam pads may be removed to make certain that the grease passages are open and that grease is getting to the wearing surfaces. **Replace the pads as they are critical to protect the wearing surfaces from damage.**



Flush Style Grease Coupler Required

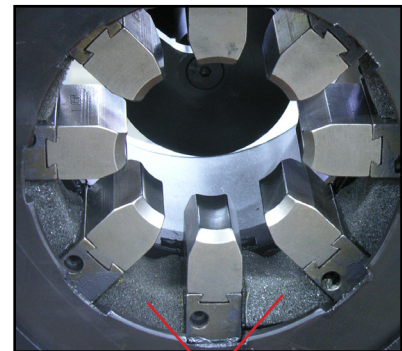
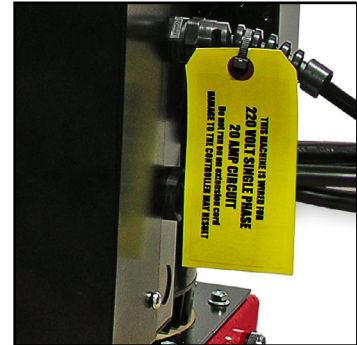

Foam Filler Pads

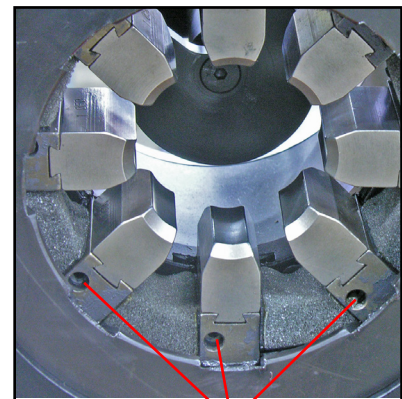

Grease Fitting Holes



CUSTOM CRIMP™

Innovating **SMART** Hose Assembly Solutions Since 1979

CRIMPING PROCEDURE

- Select the correct die set for the combination of hose and fitting being crimped. Consult the hose and fitting manufacturer's specifications for the correct die to use and final crimp diameter required.
- To insert the dies, open the master dies to the fully open position, and insert each die finger individually making certain that the die size (number stamped on the die) is correct. The die should click into place with the ball detent when it is properly positioned.
- The final crimp diameter is the closed diameter of the die stamped on the face of the die plus the number shown on the micrometer. See micrometer setting example below.

Micrometer Setting Example

Each 100 on the metric Micrometer represents 1 mm above the closed diameter of the die set. For example, with a 10mm die installed and the Micrometer set at 250, the finished crimp diameter would be 12.5 mm. (10mm + 2.5mm)

- Insert the hose and fitting in the crimper head and press and hold the green **Start/Close** button or press and hold the **Foot Switch**. When the crimper reaches the correct diameter, the crimper will shut off. When possible, the hose fitting should be centered axially in the die set to assure a uniform crimp with minimum taper.

- When the **Hold/Release** valve is in the **Hold** position, the crimper can be jogged into position to allow for more accurate positioning of the fitting in the die set. Turn the **Hold/Release** valve to the **Release** position to allow the dies to retract.

- Measure the finished crimp diameter to be certain that it is within manufacturer's specifications. If the finished diameter is not within specifications, see calibration instructions.

Note: Due to tolerance variations in hose and fitting combinations, some "offset" may be required for specific combinations of hose and fittings. This does not mean that the crimper is out of calibration.

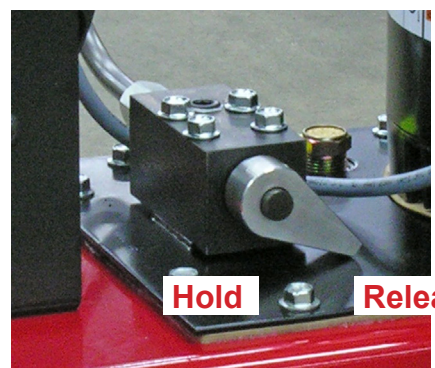
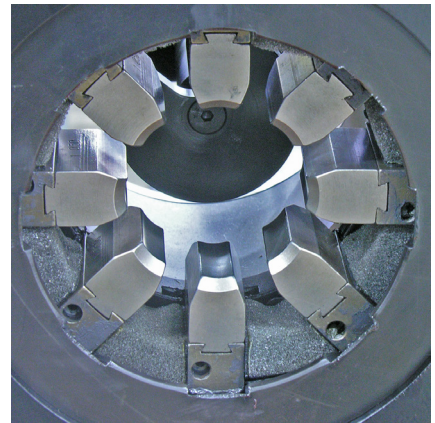

Hold

Release



CALIBRATION PROCEDURE

CALIBRATION CHECK:

While the CC15 Crimper is calibrated at the factory prior to shipment, a calibration check is recommended prior to using the crimper. Select a typical hose and fitting and set the CC15 micrometer to the hose and fitting manufacturer's recommendation. Insert the hose and fitting and press and hold the Start/Stop switch until the crimper shuts off. Measure the finished crimp. If the finished crimp diameter is not within the hose manufacturer's specifications, recalibrate the crimper.

Note: Due to variations in hose and fitting tolerances, some "offset" may be required to achieve the correct crimp diameter for specific hose and fitting combinations across the range of hose and fittings being crimped. If crimp diameters are consistently too large or consistently too small, the crimper should be recalibrated.

CALIBRATION:

While the crimper can be calibrated using any recommended hose and fitting combination, using a hose and fitting combination close to the size most frequently crimped will minimize the offset required for other sizes and combinations of hose and fittings.

- Select a hose and fitting combination recommended by the hose manufacturer and continue to adjust the Crimp Adjustment Micrometer until the correct measured crimp diameter is achieved.

For example, if there is a 10mm die set in the crimper and the required crimp diameter is 12.5mm the micrometer would be set to crimp at $10\text{mm} + 2.5\text{mm}$ or 12.5mm.

Note: The number on the Crimp Adjustment Micrometer may not agree with the hose manufacturer's specification at this point.

- If necessary, loosen the set screw on the knob with a .050 hex key wrench and rotate the knob until the setting on the knob matches the actual diameter of the finished crimp.
- Tighten the set screw
- Calibration is now complete



Knob Set Screw





TROUBLESHOOTING

PROBLEM: CRIMPER WILL NOT RUN AT ALL

- The white rocker switch is also a circuit breaker. Check to see that the circuit breaker has not been tripped.
- Check the wall outlet. Use of extension cords or outlets with inadequate power can damage the motor . Do not run the crimper from a portable power source.

PROBLEM: CRIMP DIAMETER TOO LARGE

- Check crimper calibration and recalibrate if required.
- Incorrect die being used. Each die has a range of approximately 3mm (.120 in) above the closed diameter of the die. The closed diameter is the die size stamped on the die face.
- Incorrect setting of the micrometer. Check hose manufacturer's specifications.
- Inadequate pump pressure. Check oil level in the pump. It should be 1-1/2 to 2 inches below the fill plug. Replenish with ISO Viscosity Grade 46 hydraulic oil if necessary.
- Inadequate lubrication of the master dies causing the pump to work harder than normal to reach the required diameter.
- Inadequate pressure being generated by the pump. This is most likely if the crimper can crimp the smaller size hoses and not the larger hoses. When correctly adjusted, the pump should generate approximately 5000 psi.

Do Not adjust pump to produce in excess of 5000 psi as damage to components or personal injury could result

- No pressure being generated by the pump. There should be a definite change in pitch of the pump as it cycles into high pressure mode and begins to "work" harder.

PROBLEM: CRIMP DIAMETER TOO SMALL

- Check crimp diameter and recalibrate if necessary.
- Incorrect die being used (See die range under Crimp Diameter Too Large).
- Incorrect setting of the micrometer. Check hose manufacturer's specifications.

If problem(s) persist contact Customer Service for additional troubleshooting assistance



CUSTOM CRIMP™

Innovating SMART Hose Assembly Solutions Since 1979

REPLACEMENT ACCESSORIES



Metric Dial Micrometer
P/N:102941-600



Pneumatic Pendent Switch
P/N:101349



Manual Back Stop
P/N:103907



Mini Grease Gun
P/N:103889



CRIMPX Die Lubricant 3 oz mini
grease tube P/N:103887



CRIMPX Die Lubricant 14 oz
large grease tube P/N:103888



Protective Master Die Foam Pad
P/N:103285



CustomCrimp® Notched Digital
Caliper IN/MM P/N:CC-Caliper



Die Storage Shelf
P/N:101625 (Red)



Mobile Cart
P/N:101956



COMPONENT PARTS BREAKDOWN

CC15 Machine Assembly Directory (103666)	
ITEM	DESCRIPTION
1	CC15 Crimper Head Assembly
2	1 HP 110V Motor
3	1/4-20 x 1/2 Flanged HHS
4	Pump Gasket
5	CC15/CC30 Sheetmetal Assembly
6	Mounting Bracket Assembly
7	Dial Micrometer Assembly
8	3/8 High Pressure Tubing
9	Backstop Assembly
10	Electrical Box Assembly

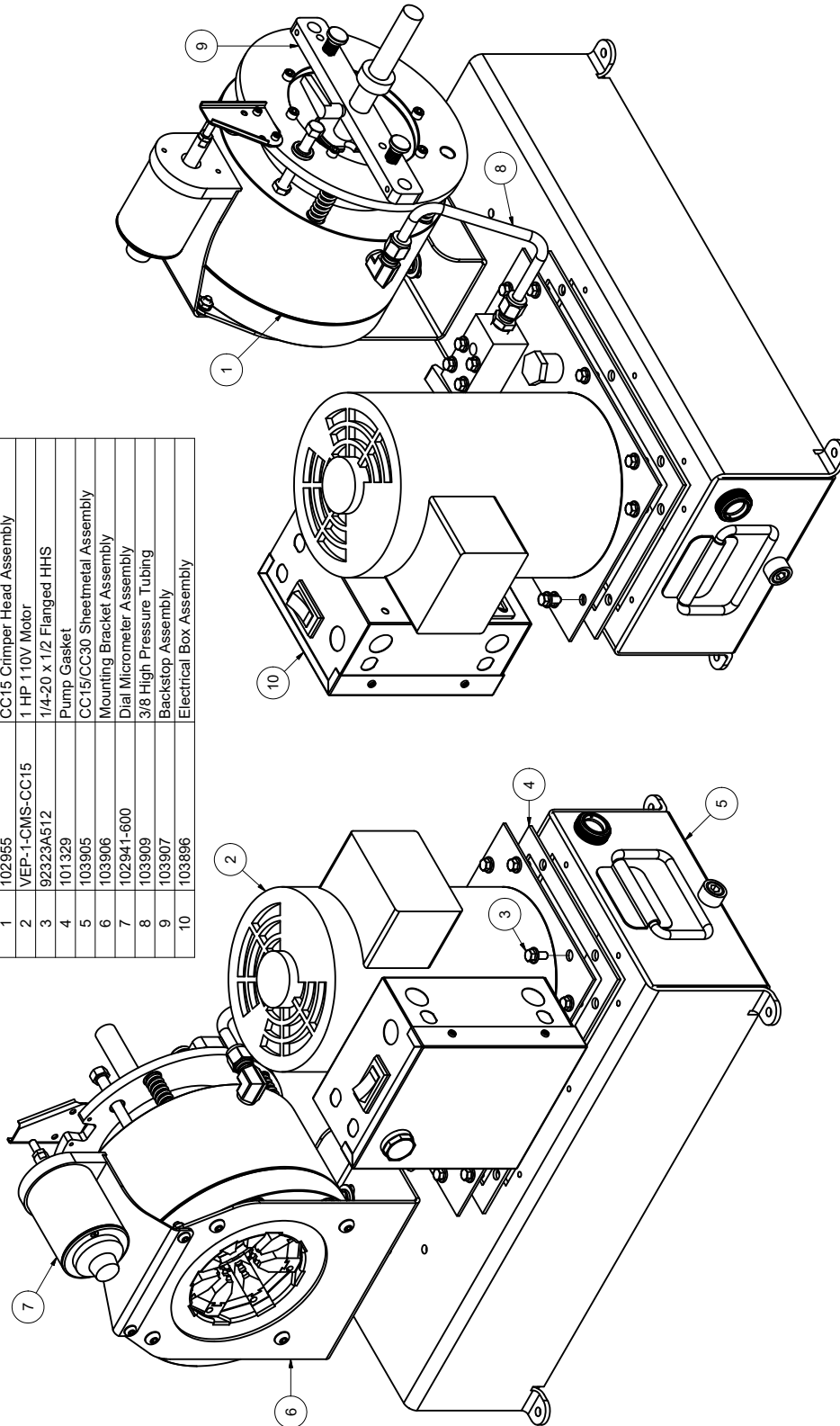



CUSTOM CRIMP™

Innovating SMART Hose Assembly Solutions Since 1979

CUSTOMCRIMP® “NO-NONSENSE” WARRANTY STATEMENT

All Custom Crimp® Products are warranted to be free of defects in workmanship and materials for one year from the date of installation. This warranty ends when the product becomes unusable for reasons other than defects in workmanship or material.

Any Custom Crimp® Product proven to be defective in workmanship or material will be repaired or replaced at no charge. To obtain benefits of this warranty, first, contact Warranty Repair Department at Custom Machining Services at **(219) 462-6128** and then deliver via prepaid transportation the complete hydraulic product to:

**ATTN: WARRANTY REPAIR DEPT.
Custom Machining Services, Inc.
318 North Co. Rd 400 East
Valparaiso IN 46383**

If any product or part manufactured by Custom Crimp® is found to be defective by Custom Crimp®, at its option, Custom Crimp® will either repair or replace the defective part or product and return via ground transportation, freight prepaid.

Custom Crimp® will not cover any incoming or outgoing freight charges for machines sold outside The United States.

This warranty does not cover any product or part which is worn out, abused, altered, used for a purpose other than for which it was intended, or used in a manner which was inconsistent with any instructions regarding its use.

Electric motors are separately warranted by their manufacturer under the conditions stated in their separate warranty.

CRIMP

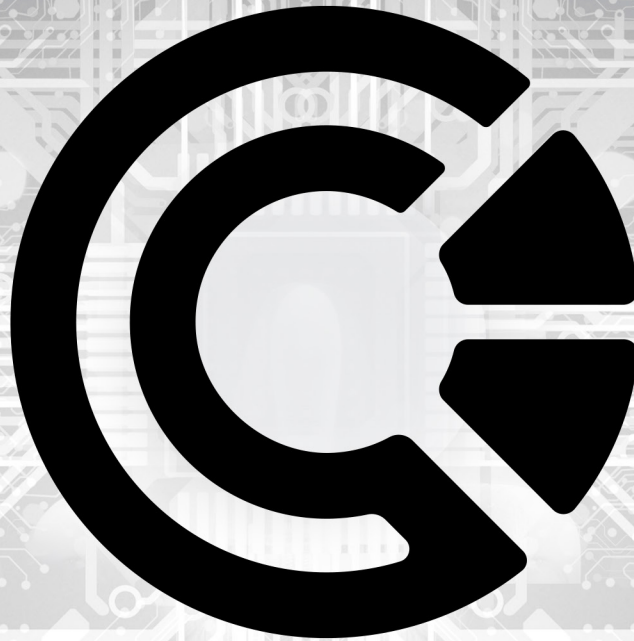

CUT

TEST

CUSTOM CRIMP®, YOUR SINGLE SOURCE FOR HOSE ASSEMBLY PRODUCTS.

CUSTOM CRIMP® | Custom Machining Services, Inc.
326 North 400 East Valparaiso, IN 46383



Visit us at: www.customcrimp.com



For sales: ccsales@customcrimp.us



For support: ccsupport@customcrimp.us



Innovating **SMART** Hose Assembly Solutions Since 1979

Custom Crimp®

www.customcrimp.com

(219) 462-6128