

HS-150 / HS-500 Hose Saws Series



The features found on these rugged, HS-150 / HS-500 HS hose saws series and the accessories included make it the best value of any hose saw in its class.



HS-150 / HS-500 HOSE SAWS SERIES OPERATORS MANUAL

HS-150 / HS-500 Hose Saws Series



SAFETY PRECAUTIONS

MODELS COVERED

This manual is applicable to different variations of the CUSTOMCRIMP® HS Series Hose Saws.



SAFETY PRECAUTIONS



- READ INSTRUCTIONS AND IDENTIFY ALL COMPONENT PARTS BEFORE USING HOSE SAW.
- MOUNT THE HS-150, OR HS-500 HOSE SAW ON A STURDY WORKBENCH.
- ALLOW THE BLADE TO REACH FULL SPEED BEFORE STARTING A CUT.
- PERIODICALLY EXAMINE THE BLADE FOR CRACKS AND / OR BROKEN TEETH.
- REPLACE IF NECESSARY.
- KEEP BOTH HANDS AWAY FROM THE CUTTING BLADE.
- DO NOT REMOVE OR DEFEAT ANY OF THE GUARDS OR SAFETY FEATURES OF THE SAW.
- ALWAYS WEAR EYE PROTECTION, DUST MASK, AND PROTECTIVE GLOVES.

HS-150 / HS-500 Hose Saws Series



TABLE OF CONTENT

SAFETY PRECAUTIONS-----	2
HS HOSE SAWS SERIES & TECHNICAL DATA-----	4
INITIAL SET UP-----	5
HS-150 / HS-500 INCLUDED TOOLING-----	6
HS-150 / HS-500 OPTIONAL PARTS-----	7
HS-150 / HS-500 BLADE AWARENESS-----	9
HS-150 / HS-500 HOSE HELPER SET UP-----	10
HS-150 / HS-500 HOSE BENDING PINS SET UP-----	11
HOW TO CHANGE THE SAW BLADE-----	12
HOW TO INSERT THE VACUUM ATTACHMENT-----	14
INSTALLATION & SET UP OF THE HS-500 MISTER KIT-----	15
ADJUST AIR PRESSURE & OIL DROPS-----	17
HS-150 / HS-500 REPLACEMENT ACCESSORIES-----	18
COMPONENT PARTS BREAKDOWN-----	19
CUSTOMCRIMP® “NO-NONSENSE” WARRANTY STATEMENT-----	24
CUSTOMCRIMP® CONTACT INFORMATION-----	25

HS-150 / HS-500 Hose Saws Series



HOSE SAWS SERIES TECHNICAL DATA

These rugged, HS-150 / HS-500 dependable saws offer features not found on other saws. Choose the one with the capacity and features which meet your individual requirements.



HS-150	HS-500
Capacity: Up to 1-1/4" 4SP	Capacity: Up to 2" 6SP
Dimensions: L: 28-3/4" x W: 21" x H: 12-1/4"	Dimensions: L: 29-3/4" x W: 26-3/4" x H: 16"
Weight: 70 lbs	Weight: 120 lbs
Power: 1HP/230V/1Phase (Standard) 1HP/110V/1Phase (Optional) 1HP/12VDC/24VDC (Optional)	Power: 5HP/230V/3Phase (Standard) 5HP/480V/3Phase (Optional) 5HP/230V/1Phase (Optional)

AVAILABLE MOBILE HOSE SAWS



HS-150 12VDC HOSE SAW SERIES



HS-150 24VDC HOSE SAW SERIES

Ideal for on-site service where electricity is not available.
For more information contact custom crimp® customer service.

HS-150 / HS-500 Hose Saws Series



INITIAL SET UP

FOLLOW THESE STEPS BEFORE YOU USE YOUR HS SERIES HOSE SAW FOR THE FIRST TIME.

- Mount your HS Series Hose Saw on a sturdy workbench in a well-lit area. Workbench should be able to support the hose saw weight.



- Check electrical circuit to be certain that it matches the hose saw requirements shown on the tag attached to the hose saw cord.

DO NOT USE AN EXTENSION CORD OR RUN FROM PORTABLE POWER SOURCES AS LOW VOLTAGE CAN DAMAGE THE MOTOR.



- Check to be certain that the blade rotates in the direction of the arrow shown on the motor housing.

Note: Blade also has a rotation arrow.



Note: New blades must be properly conditioned to assure long life and clean cuts. For the first ten cuts, feed the blade slowly through a medium size hose. This will properly break in and condition the blade for long life.



HS-150 / HS-500 Hose Saws Series



HS-150 / HS-500 INCLUDED TOOLING

- **Hose Helper**

Included only for HS-500 Series.
Not available for HS-150.

A "Hose Helper" attachment for the HS-500 prevents the hose from being drawn back during a cut and gives the operator the ability to more precisely control the cut length. The "Hose Helper" can be mounted on either end of the saw.

- **Hose Bending Pins**

Included for all HS-150 / HS-500 Series.

Hose Bending Pins prevent the blade from binding during a cut.

- **Serrated Blade (General Purpose)**

Included for all HS-150 / HS-500 Series.

Is an aggressive, universal blade that cuts multi-spiral and braided hose very well.

- **Counter**

Included only for HS-500 Series.
Not available for HS-150.

A resettable counter makes it easy to keep track of the number of cuts made.

- **1 1/4" Vacuum Adapter**

(For 2 1/2" shop vac, or vacuum accessories).

Included for all HS-150 / HS-500 Series.

Vacuum port allow attachment of vacuum system to keep saw and work space clean.



HS-150 / HS-500 Hose Saws Series



HS-150 / HS-500 OPTIONAL PARTS

- **Mister Hose Assembly**

Optional only for HS-500 Series.
Not available for HS-150.

The mister sprays a fine mist of air tool oil on the saw blade for longer blade life and cleaner cuts.



- **Hose Channel System**

Available in 5 foot sections only for HS-500 Series.

The Hose Channel System both measures and supports the hoses up to 2 inch diameter as they are being cut.



- **Mobile Cart**

Optional for all HS-150 / HS-500 Series.

HS hose saw model, can be mounted on the mobile cart for easy moving around the shop.

Mobile Cart comes with (2) lockable swivel casters.



The HS-500 Series hose saw is shown, mounted on the mobile cart with the hose helper and hose channel installed.



HS-150 / HS-500 Hose Saws Series



HS-150 / HS-500 OPTIONAL PARTS

- **Scalloped Blade (General Purpose)**

Available for all HS-150 / HS-500 Series.



- **Double Bevel Blade with SS Slots**

Available for all HS-150 / HS-500 Series.



Hose Saw Model	Blade Type	Blade Size Diameter	Arbor Size	Part Number
HS-150	Serrated (Included)	10 inch	1 inch	103502
	Scalloped (Available)	10 inch	1 inch	104034
	Double Bevel w/ SS Slots (Available)	10 inch	1 inch	104050
HS-500	Serrated (Included)	12 inch	1 inch	103187
	Scalloped (Available)	12 inch	1 inch	104033
	Double Bevel w/ SS Slots (Available)	12 inch	1 inch	102210

For more, information contact custom crimp® customer service.

HS-150 / HS-500 Hose Saws Series



HS-150 / HS-500 BLADE AWARENESS

Note: New blades must be properly conditioned to assure long life and clean cuts. For the first ten cuts, feed the blade slowly through a medium size hose. this will properly break in and condition the blade for long life.

Note: The hose should begin to bend before contacting the blade. This will increase blade life and keep the hose from tearing and deforming.

Note: Once the blade and motor reach full RPM apply steady downward pressure on the handle in order to force the hose into the blade. Do not apply enough force to stall the blade, and ease up on the pressure before the blade completes the cut. This will keep from separating the wires as the blade exits the hose.

Note: The edges of the blade may appear to be dull. This does not mean that the blade is not effective.

As long as the blade is still giving clean cuts, do not replace the blade.

NOTE: PAY CLOSE ATTENTION TO THE DIRECTION OF ROTATION MARKED ON THE SERRATED BLADE.

IT IS THE OPPOSITE OF MOST BLADES OF THIS TYPE.

CAUTION: Cracks can cause extremely damage to the blade, periodically examine the blade for cracks and / or broken teeth.



Serrated Blade



Scalloped Blade



Double Bevel w/SS Slots Blade



Damaged Blade

HS-150 / HS-500 Hose Saws Series



HS-500 HOSE HELPER SET UP

Step 1

To set hose helper, loosen locking knob and lift the retraction.

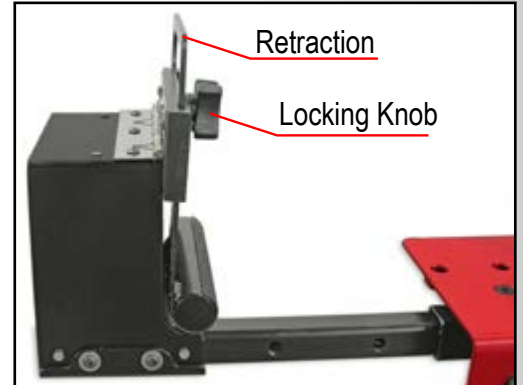

Step 2

Feed the hose through from the rear end, and set retraction a slight angle and tighten locking knob.

This will prevent hose from back feeding from cutting area.



[Extra Features of the Hose Helper](#)

The hose helper has multi mounting positions, can be adjusted up to 10" away from hose saw base.

With the hose helper extension attached, can be adjusted up to 22" away from the hose saw base.

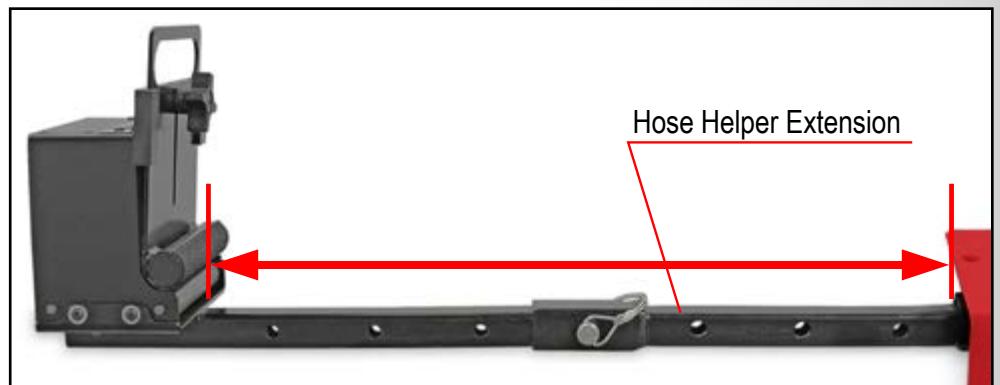
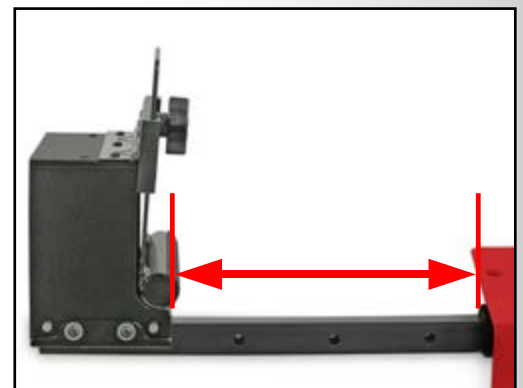

HS-150 / HS-500 Hose Saws Series



HS-150 / HS-500 HOSE BENDING PINS SET UP

Hose Bending Pins Set UP

All the HS-150 / HS-500 series hose saws have a "Hose Bending Pins Position" decal placed on top of the hose saw.

Step 1

Position the hose bending pins according to the hose size.

For example for a 1/2 inch hose, position the pins in the hole closest to the blade.

Note: Pins **MUST** be positioned in the holes in the saw table such that the hose opens slightly during the cut. Spread the pins further apart for larger hoses.

Step 2

Turn on the hose saw, apply steady downward pressure on the handle in order to force the hose into the blade.

As you making a cut, the hose bending pins will allow the hose to bend as shown in the picture, this will minimize the friction during the cut.

Step 3

For a (larger) 2 inch hose, position the pins further out as shown in the picture.



HS-150 / HS-500 Hose Saws Series



HOW TO CHANGE THE SAW BLADE

Step 1

MAKE CERTAIN THAT THE HOSE SAW IS TURNED OFF AND UNPLUG IT.

WEAR SAFETY GLASSES AND PROTECTIVE GLOVES AT ALL TIMES WHEN CHANGING SAW BLADE AND OPERATING THE HOSE SAW.

Step 2

Use a 5/32 inch Allen wrench to remove the 5 screws, and the side access panel.

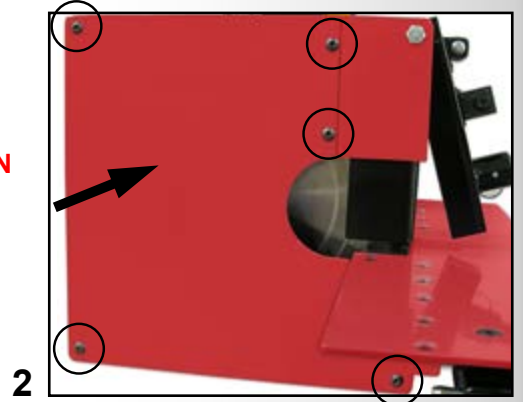

Step 3

Use 1/8 inch Allen wrench to remove the 2 screws, and the Black Saw Blade Access Panel to provide clearance to remove the blade.

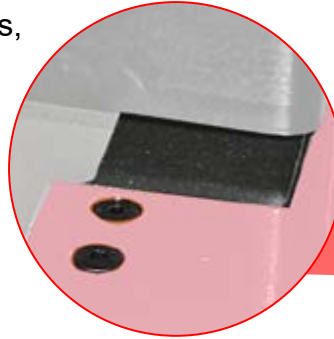

Step 4

For HS-150 series, use a 1" wrench.
For HS-500 series, use a 1-1/4" wrench to keep the Motor Shaft Arbor in place.

Note: there is a notch on the motor shaft arbor where the wrench falls into place.



Step 5

Use a 1-1/2" wrench or an adjustable wrench to lose the Hex Jam Nut, remove it and the Blade Grip as well.

Note: Pay close attention to the tighten rotation arrow on the hex jam nut, this is a left handed hex jam nut.

Note: To lose the hex jam nut would be clockwise, and to tighten it would be counter-clockwise.

Tighten Rotation Arrow

Hex Jam Nut

Blade Grip

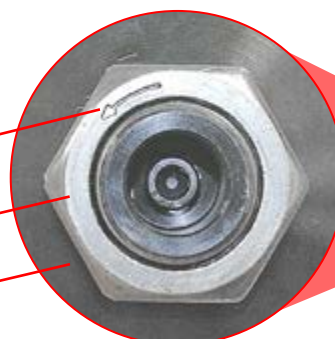

HS-150 / HS-500 Hose Saws Series



HOW TO CHANGE THE SAW BLADE

Step 6

Remove the old blade.

Note: Be careful when removing the old blade.

Note: Always wear safety glasses and protective gloves when changing blade and operating the hose saw.

Step 7

Use an air gun or a clean rag to clean the inside to remove any debris.

Step 8

Make certain that the new blade does not have any broken teeth, cracks or any other damage before installing.

Step 9

Before installing the new blade, if the blade has a rotation arrow make certain that the blade is installed so that it rotates in the direction of the arrow.

Note: Once the new blade is installed, repeat the process in reverse order to install all the parts back on the hose saw.

Note: To lose the hex jam nut would be clockwise, and to tighten it would be counter-clockwise.

DO NOT OPERATE THE SAW WITHOUT
ALL OF THE GUARDS IN PLACE

6



7



8



9



HS-150 / HS-500 Hose Saws Series



HOW TO INSERT THE VACUUM ATTACHMENT

Step 1

MAKE CERTAIN THAT THE HOSE SAW IS TURNED OFF AND UNPLUG IT.

WEAR SAFETY GLASSES AND PROTECTIVE GLOVES AT ALL TIMES WHEN OPERATING THE HOSE SAW.

- 1 ¼" Vacuum Port located on rear of hose saw.
Available in all HS-150 / HS-500 Series.

Note: Do not recommend using at the same time as Mister.

Step 2

Remove Plastic Plug (A).



Step 3

Insert supplied 1 ¼" Vacuum Attachment (B).
(For 2 ½" shop vac, or vacuum accessories).



Step 4

Run vacuum during cutting process.



HS-150 / HS-500 Hose Saws Series



INSTALLATION AND SET UP OF THE MISTER HOSE ASSEMBLY

Step 1

MAKE CERTAIN THAT THE HOSE SAW IS TURNED OFF AND UNPLUG IT.

WEAR SAFETY GLASSES AND PROTECTIVE GLOVES AT ALL TIMES WHEN INSTALLING THE MISTER HOSE ASSEMBLY AND OPERATING THE HOSE SAW.

The following procedures can be used to install the Mister Hose Assembly on the HS-500 Series hose saws. (Not available for HS-150 Series).

Step 2

Remove the Mister Hose Assembly from its packaging and verify that all components are properly installed and all fittings are securely tightened as shown, and then follow the steps below to install the Mister Hose Assembly.

Step 3

Verify that the hose saw is turned off and unplugged. Remove the bolts and black cover from the Hose Mister Access (A).

Step 4

Insert the Hose Manifold Mister into the Hose Mister Access, and secure it with the 1/4 - 20 x 3/4" Hex Bolts provided (B).

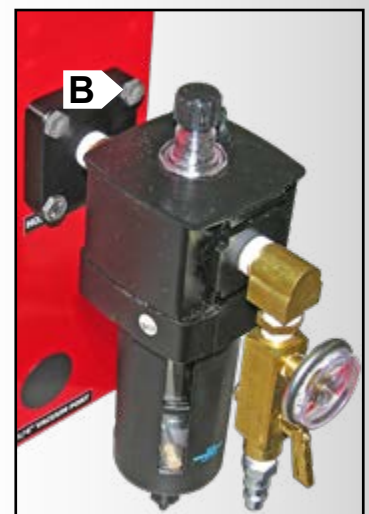
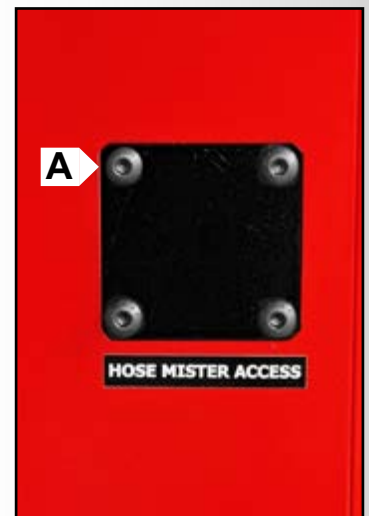

HS-150 / HS-500 Hose Saws Series



INSTALLATION AND SET UP OF THE MISTER HOSE ASSEMBLY

Step 5

Remove the Fill Plug located on the top of the Mister Lubricator (C).



Step 6

Pour 1 bottle of 4 oz of mister oil into the fill port (D). Then thread the Fill Plug back in.

Note: 2 bottles of 4 oz of mister oil are included, please note reservoir only holds 4 oz (Mister Oil part number P/N:104156).



HS-150 / HS-500 Hose Saws Series



ADJUST AIR PRESSURE & OIL DROPS

Step 1

MAKE CERTAIN THAT THE HOSE SAW IS TURNED OFF AND UNPLUG IT. WEAR SAFETY GLASSES AND PROTECTIVE GLOVES AT ALL TIMES WHEN INSTALLING THE MISTER HOSE ASSEMBLY AND OPERATING THE HOSE SAW.

Step 2

Use a 5/32 inch Allen wrench to remove the 5 screws, and the side access panel (E).

Step 3

Connect air line using quick connect (F).

Step 4

Set air pressure by adjusting valve on the air regulator (G).

Step 5

Adjust the oil drops (H) so that after approximately 10 seconds you see a small film appear onto the hose saw blade (I).

Note: If the sound of the air going against the blade is too loud, reduce the air pressure and increase the oil drop. Adjust the air pressure to a more comfortable level, then verify that you are getting your small film coverage in approximately 10 seconds.

Step 6

When the hose saw is not in use you can turn off the mister by either option:

A. Un-hook the air disconnect (this allows you not to have to adjust the air pressure each time).

B. Turn off the air regulator (If you use this option we recommend making a mark on your air pressure gage to show what the desired setting is for quick setup).

Step 7

Place the side panel and tighten the bolts back on the hose saw.

The installation and setup of the Mister Hose Assembly have been completed.



HS-150 / HS-500 Hose Saws Series



HS-150 / HS-500 REPLACEMENT ACCESSORIES

*Only available for the HS-500 model



*Mister Hose Assembly
P/N:103172



*Mister Oil 4 oz bottle
P/N:104156



*Hose Channel System
P/N:103073



*Hose Helper
P/N:103297



*Hose Saw Counter
P/N:1895T42

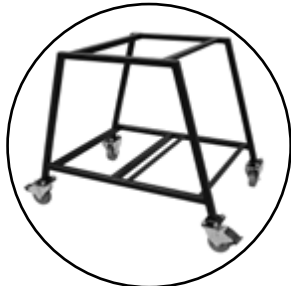

Mobile Cart
P/N:101956



Serrated Blade



Scalloped Blade



Double Bevel Blade
with SS Slots



Hose Saw Model	Blade Type	Blade Size Diameter	Arbor Size	Part Number
HS-150	Serrated (Included)	10 inch	1 inch	103502
	Scalloped (Available)	10 inch	1 inch	104034
	Double Bevel w/ SS Slots (Available)	10 inch	1 inch	104050
HS-500	Serrated (Included)	12 inch	1 inch	103187
	Scalloped (Available)	12 inch	1 inch	104033
	Double Bevel w/ SS Slots (Available)	12 inch	1 inch	102210

For more, information contact customcrimp@customer.service.

HS-150 / HS-500 Hose Saws Series



COMPONENT PARTS BREAKDOWN

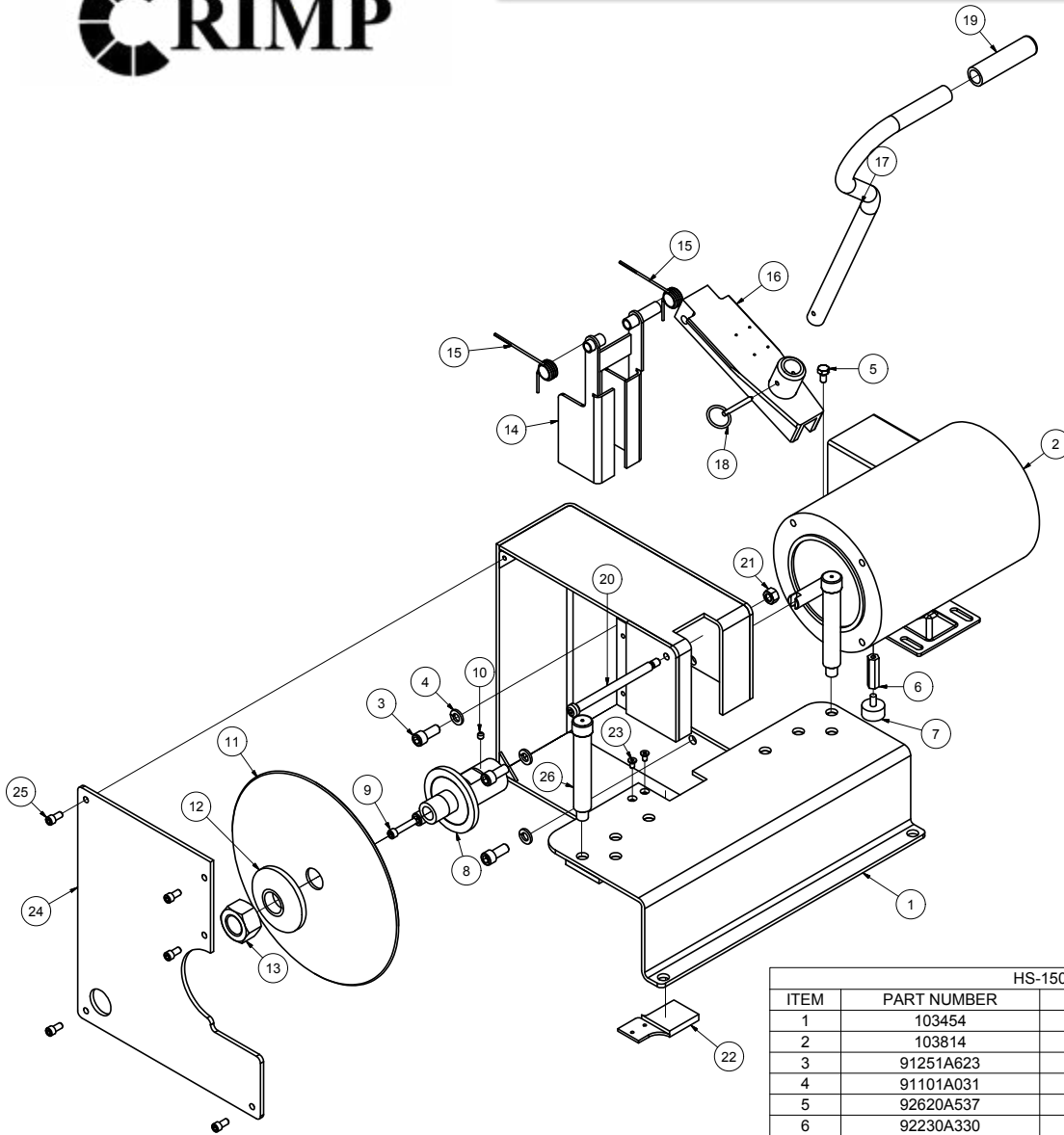

HS-150 ASSEMBLY (103734)

ITEM	PART NUMBER	DESCRIPTION	QTY
1	103454	HS150 BASE ASSEMBLY	1
2	103814	1 HP 110V 3600RPM MOTOR	1
3	91251A623	3/8-16 X 7/8 SHCS	4
4	91101A031	3/8 LOCK WASHER	4
5	92620A537	1/4-20 X 1/2 HHS	1
6	92230A330	1/4-20 X 1-1/2" HEX STANDOFF	1
7	103774	1/4-20 RUBBER VIBRATION FOOT	1
8	103299	HS-150 5/8" MOTOR SHAFT ARBOR	1
8	103127	HS-300/500 5/8" MOTOR SHAFT ARBOR	1
9	91251A544	1/4-20 X 1 1/4 SHCS	1
10	91375A533	1/4-20 X 1/4 SET SCREW	1
11	103502	10 INCH SERRATED BLADE	1
12	102391	HS-150/300/500 BLADE GRIP	1
13	90083A260	1/14 LEFT HAND JAM NUT	1
14	102706	HS-150/300/500 SAFETY GUARD ASSEMBLY	1
15	9271K67-CCW	CCW TORSION SPRING - RIGHT SIDE	1
15	9271K67-CW	CW TORSION SPRING - LEFT SIDE	2
16	102699	HS-150/300/500 PUSHER BASE	1
17	102697	HS-150/300/500 HANDLE	1
18	98320A013	3/16 X 1.3 PULL PIN	1
19	103815	BLACK HAND GRIP	1
20	91247A644	3/8-16 X 4 1/2 SHOULDER SHCS	1
21	90566A031	3/8 NYLOC JAM NUT	1
22	102926	HS-150/300/500 SAW BLADE ACCESS PANEL	1
23	91253A240	10-24 X 3/8 FHCS	2
24	103476	HS150 ACCESS PANEL	1
25	91306A375	1/4-20 X 1/2 SHCS	5
26	103665	HS-150/300/500 LOCATING PIN ASSEMBLY	2

HS-150 / HS-500 Hose Saws Series



COMPONENT PARTS BREAKDOWN

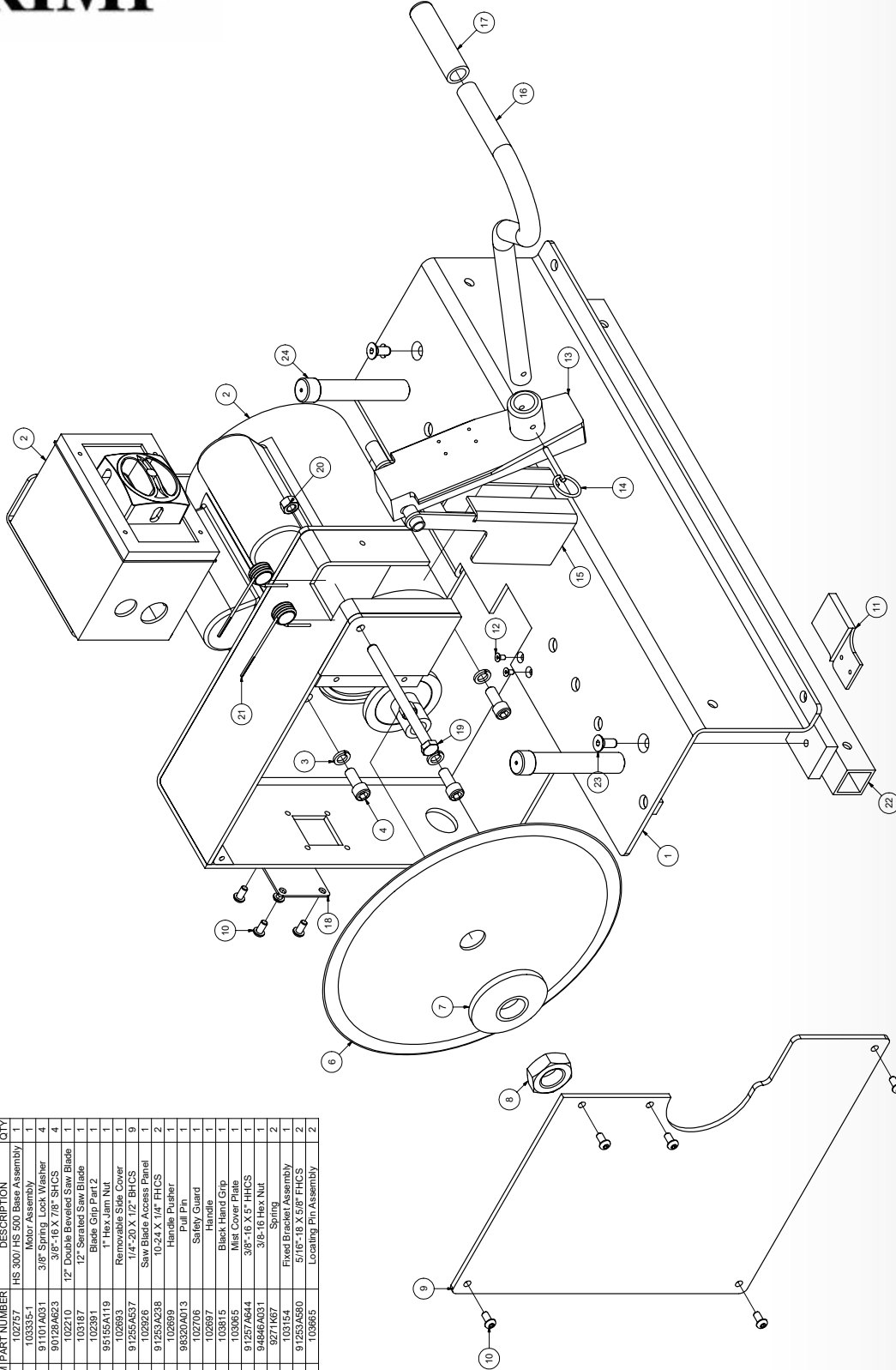

ITEM PART NUMBER	DESCRIPTION	QTY
1	HS 300/HS 500 ASSEMBLY (103335)	1
2	HS 300/HS 500 Base Assembly	1
3	3/8" Spray Nozzle Washer	4
4	3/8"-18 X 7/8" SHCS	4
5	10-24 X 1/2" Double Beveled Saw Blade	1
6	12" Serrated Saw Blade	1
7	Blade Grip Part 2	1
8	95155A119 1" Hex Jam Nut	1
9	Removable Side Cover	1
10	91255A537 1/4"-20 X 1/2" BHCS	9
11	102926 Saw Blade Access Panel	1
12	91253A338 10-24 X 1/4" FHCS	2
13	102699 Handle Pusher	1
14	98320A013 Pull Pin	1
15	102705 Safety Guard	1
16	102697 Handle	1
17	Black Hand Grip	1
18	103815 Jam Nut	1
19	91257A644 3/8"-16 X 5/8" HHCS	1
20	94846A031 3/8-16 Hex Nut	1
21	9271A67 Spring	2
22	103154 Fixed Bracket Assembly	1
23	91253A590 5/16"-18 X 5/8" FHCS	2
24	103665 Locating Pin Assembly	2

HS-150 / HS-500 Hose Saws Series



COMPONENT PARTS BREAKDOWN

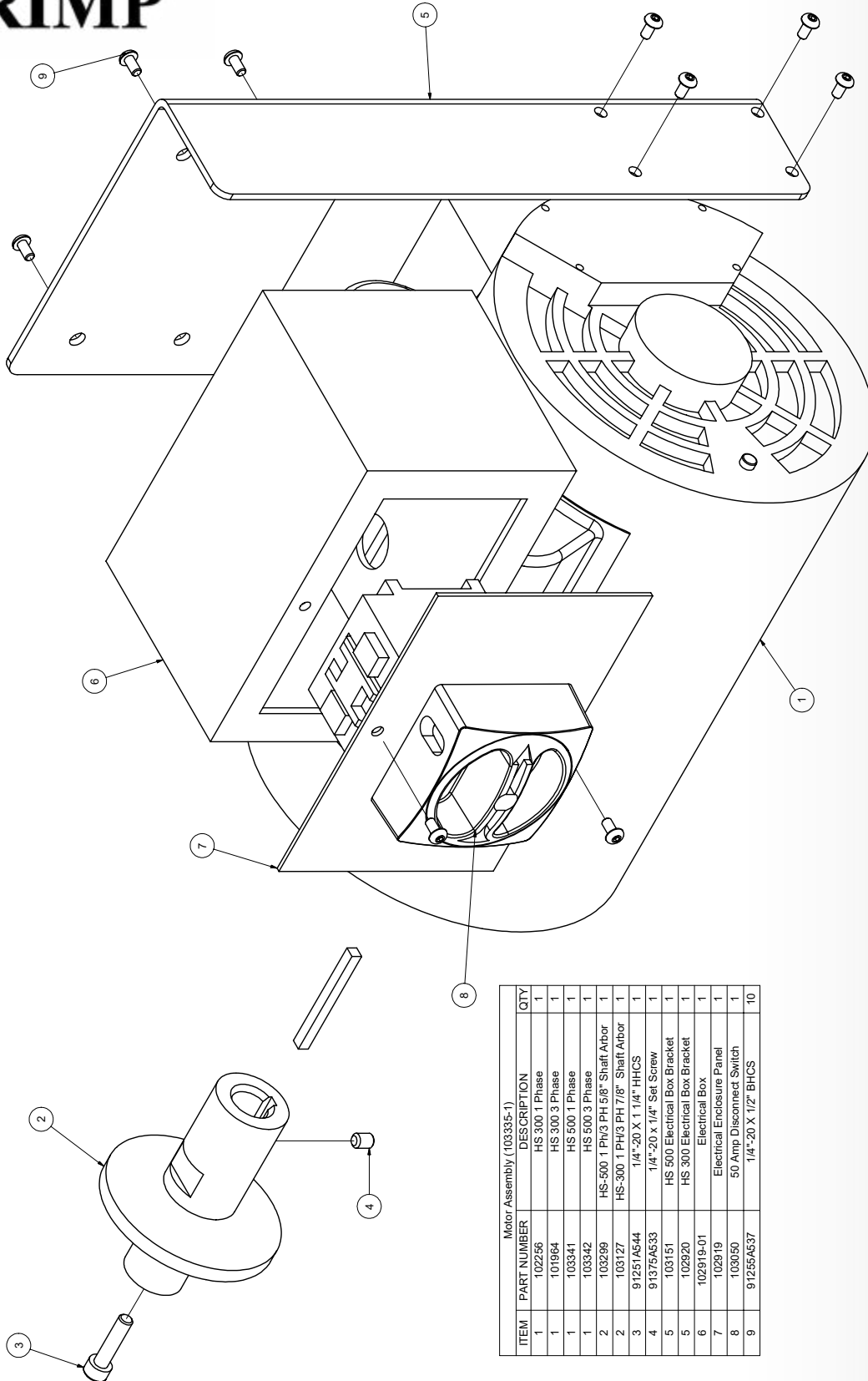

Motor Assembly (103335-1)			QTY
ITEM	PART NUMBER	DESCRIPTION	
1	102256	HS 300 1 Phase	1
1	101964	HS 300 3 Phase	1
1	103341	HS 500 1 Phase	1
1	103342	HS 500 3 Phase	1
2	103299	HS-500 1 PH/3 PH 5/8" Shaft Arbor	1
2	103127	HS-300 1 PH/3 PH 7/8" Shaft Arbor	1
3	91251A544	1/4"-20 X 1 1/4" HHCS	1
4	91375A533	1/4"-20 x 1/4" Set Screw	1
5	103151	HS 500 Electrical Box Bracket	1
5	102920	HS 300 Electrical Box Bracket	1
6	102919-01	Electrical Box	1
7	102919	Electrical Enclosure Panel	1
8	103050	50 Amp Disconnect Switch	1
9	91255A537	1/4"-20 X 1/2" BHCS	10

HS-150 / HS-500 Hose Saws Series



COMPONENT PARTS BREAKDOWN

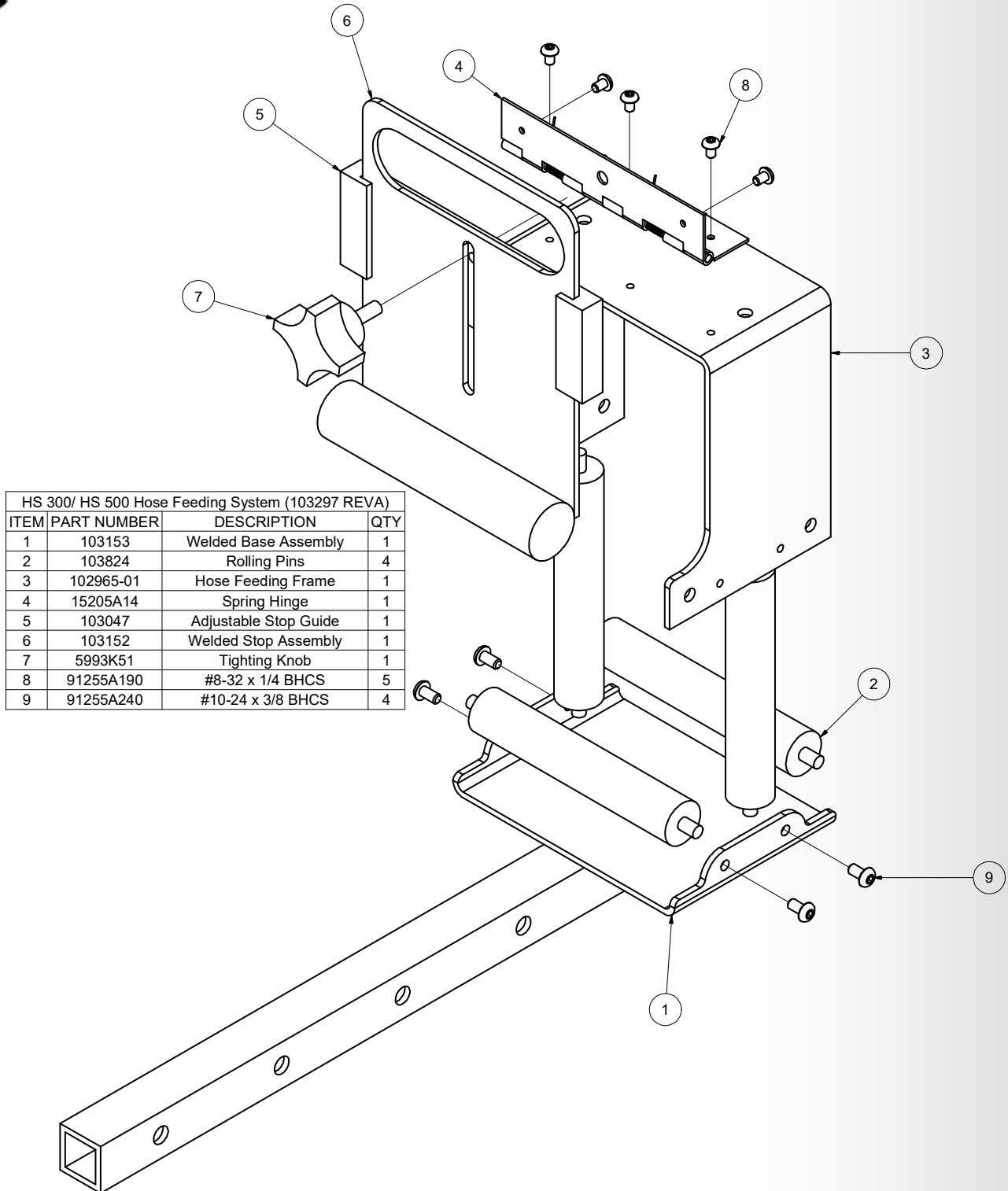

HS 300/ HS 500 Hose Feeding System (103297 REVA)			
ITEM	PART NUMBER	DESCRIPTION	QTY
1	103153	Welded Base Assembly	1
2	103824	Rolling Pins	4
3	102965-01	Hose Feeding Frame	1
4	15205A14	Spring Hinge	1
5	103047	Adjustable Stop Guide	1
6	103152	Welded Stop Assembly	1
7	5993K51	Tighting Knob	1
8	91255A190	#8-32 x 1/4 BHCS	5
9	91255A240	#10-24 x 3/8 BHCS	4

HS-150 / HS-500 Hose Saws Series



COMPONENT PARTS BREAKDOWN

HS 300/500 Mister Kit Assembly (103172)			
ITEM	PART NUMBER	DESCRIPTION	QTY
1	103168	HS 300/500 Hose Manifold Mister	1
2	4568K152	Male-Male 3/8" NPT Fitting	1
3	103822	Modular Air Line Lubricator	1
4	50785K44	3/8" Male-Female 90 deg Elbow	1
5	50785K63	3/8" to 1/4" Male-Female Hex Bushing	1
6	103823	Inline Mini Air Regulator	1
7	6534K46	Air Line Quick Connect	1
8	91255A540	1/4 - 20 x 3/4" BHCS	4

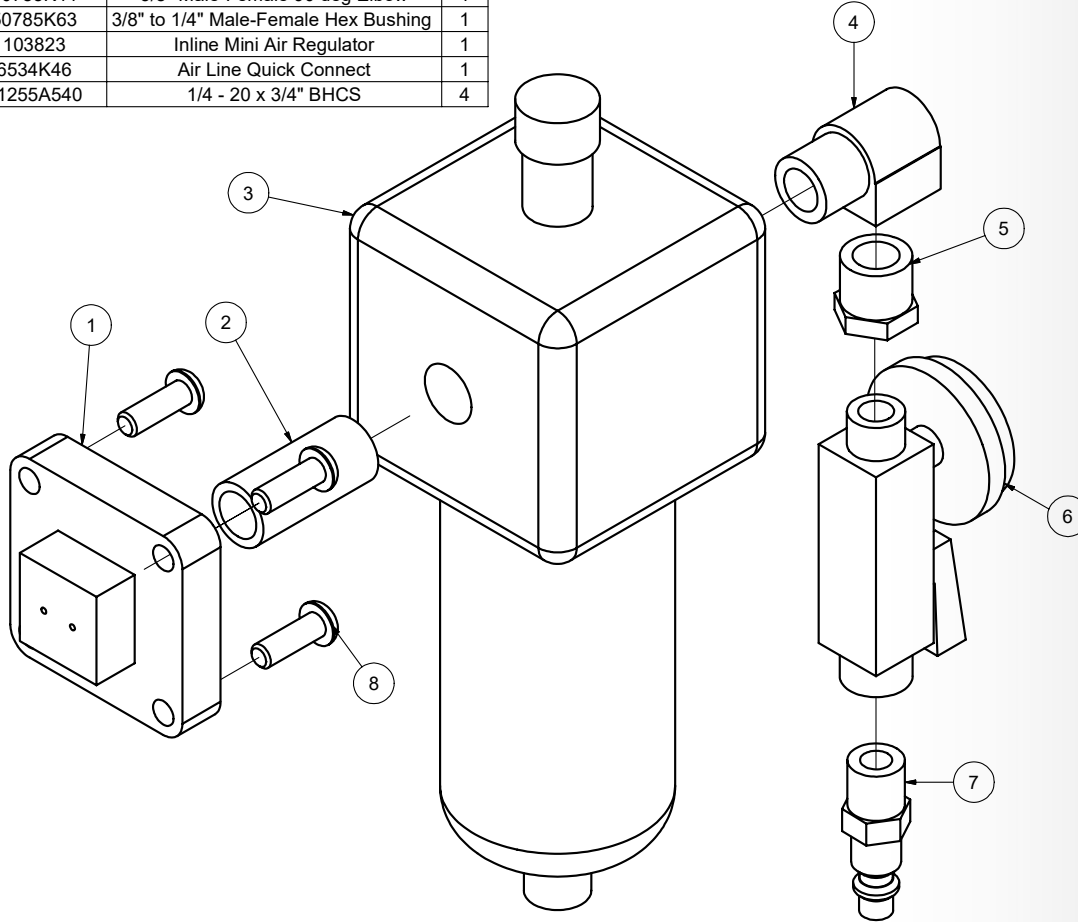

HS-150 / HS-500 Hose Saws Series



CUSTOMCRIMP® “NO-NONSENSE” WARRANTY STATEMENT



CustomCrimp® “No-Nonsense” Warranty Statement

All CustomCrimp® Products are warranted to be free of defects in workmanship and materials for one year from the date of installation. This warranty ends when the product becomes unusable for reasons other than defects in workmanship or material.

Any CustomCrimp® Product proven to be defective in workmanship or material will be repaired or replaced at no charge. To obtain benefits of this warranty, first, contact Warranty Repair Department at Custom Machining Services at **(219) 462-6128** and then deliver via prepaid transportation the complete hydraulic product to:

**ATTN: WARRANTY REPAIR DEPT.
Custom Machining Services, Inc.
318 North Co. Rd 400 East
Valparaiso IN 46383**

If any product or part manufactured by CustomCrimp® is found to be defective by CustomCrimp®, at its option, CustomCrimp® will either repair or replace the defective part or product and return via ground transportation, freight prepaid.

CustomCrimp® will not cover any incoming or outgoing freight charges for machines sold outside The United States.

This warranty does not cover any product or part which is worn out, abused, altered, used for a purpose other than for which it was intended, or used in a manner which was inconsistent with any instructions regarding its use.

Electric motors are separately warranted by their manufacturer under the conditions stated in their separate warranty.

HS-150 / HS-500 Hose Saws Series



CONTACT US

CUSTOMCRIMP®, YOUR SINGLE SOURCE FOR HOSE ASSEMBLY PRODUCTS.

Products and services to support industry wide hose assembly needs.

CustomCrimp®
Custom Machining Services, Inc.
326 N. County Rd. 400 East
Valparaiso, IN 46383
Ph: (219) 462-6128
Fax: (219) 464-2773
www.customcrimp.com



Custom Crimp®

See the complete line of Custom Crimp® Crimpers and Accessories at:

www.customcrimp.com

(219) 462-6128