



CUSTOM CRIMP™

Innovating SMART Hose Assembly Solutions Since 1979



D160S-T420 PORTABLE SERIES HYDRAULIC CRIMPERS WITH LED INDICATOR LIGHT OPERATORS MANUAL



CUSTOM CRIMP™

Innovating **SMART** Hose Assembly Solutions Since 1979



SAFETY PRECAUTIONS



- READ INSTRUCTIONS AND IDENTIFY ALL COMPONENT PARTS BEFORE USING CRIMPER.
- D160S-T420 SERIES CRIMPERS CAN PRODUCE 62 TONS OF CRIMPING FORCE.
- KEEP BOTH HANDS AWAY FROM PINCH POINTS.
- CONSULT HOSE AND FITTING MANUFACTURER FOR CORRECT MACHINE SETTINGS AND CRIMP MEASUREMENTS.
- ALWAYS WEAR EYE PROTECTION.



CUSTOM CRIMP™

Innovating **SMART** Hose Assembly Solutions Since 1979

TABLE OF CONTENT

SAFETY PRECAUTIONS-----	2
BULLETIN MICRO-CRIMP SIGHT INDICATOR / LED INDICATOR LIGHT SERIES-----	4
HOW TO REPLACE THE LED INDICATOR LIGHT BATTERIES-----	5
COMPONENT PARTS & TECHNICAL DATA-----	6
D160S-T420 PORTABLE SERIES CRIMPERS-----	7
FEATURES-----	8
INITIAL SET UP-----	9
LUBRICATION PROCEDURE-----	10
CRIMPING WITH STANDARD T420 PRESSURE PLATE-----	11
CRIMPING WITH NOTCHED T420 PRESSURE PLATE-----	16
CALIBRATION CHECK PROCEDURE-----	21
INCLUDED ACCESSORIES-----	24
AVAILABLE ACCESSORIES-----	25
TROUBLESHOOTING-----	26
COMPONENT PARTS BREAKDOWN-----	27
CUSTOM CRIMP® “NO-NONSENSE” WARRANTY STATEMENT-----	31
CUSTOM CRIMP® CONTACT INFORMATION-----	32



CUSTOM CRIMP™

Innovating SMART Hose Assembly Solutions Since 1979

BULLETIN: D160S-T420 series crimpers with Micro-Crimp Sight Indicator button have been upgraded with LED Indicator Light.



D160S-T420 SERIES CRIMPER WITH MICRO-CRIMP SIGHT INDICATOR BUTTON

STYLE: MICRO-CRIMP SIGHT INDICATOR BUTTON

CRIMPING PROCEDURE:

- Make sure the cone base is lubricated.
- Place the lubricated die set in the cone base.
- Align the fitting in the die set.
- Place the lubricated pressure plate over the die set.
- Slide the pusher onto the pusher retaining ring on the hydraulic cylinder.
- Set the Micro-Crimp Adjuster to the setting desired.
- Apply pressure to the (Hand or Pneumatic Pump) **until the Micro-Crimp sight indicator button is just visible.**
- Release pressure so the pusher will retract.
- Check the final crimp diameter with calipers to confirm that it is within manufacturer's specifications.



UPGRADED WITH LED INDICATOR LIGHT

STYLE: LED INDICATOR LIGHT

CRIMPING PROCEDURE:

- Make sure the cone base is lubricated.
- Place the lubricated die set in the cone base.
- Align the fitting in the die set.
- Place the lubricated pressure plate over the die set.
- Slide the pusher onto the pusher retaining ring on the hydraulic cylinder.
- Set the Micro-Crimp Adjuster to the setting desired.
- Apply pressure to the (Hand or Pneumatic Pump) **until the LED Indicator Light turns on.**
- Release pressure so the pusher will retract.
- Check the final crimp diameter with calipers to confirm that it is within manufacturer's specifications.

FEATURES:

- Visual RED LED Indicator Light turned on, to indicate the crimp is complete.
- No other adjustment than the Micrometer.
- Takes guesswork out of the crimping process.



HOW TO REPLACE THE LED INDICATOR LIGHT BATTERIES



The LED Indicator Light beginning to diminish.



1



2



3



4

Note: If the LED Indicator Light becomes diminish/weak/and or if the LED indicator does not light up, replace the (2) AA batteries as needed.

1. Use a # 0 Phillip-head screwdriver, to remove the screw.
2. Slide the cover towards the back to remove it.
3. Replace the (2) AA batteries.
4. Slide the cover towards the front until it locks into place, and secure it with the screw.



CUSTOM CRIMP™

Innovating SMART Hose Assembly Solutions Since 1979

COMPONENT PARTS & TECHNICAL DATA

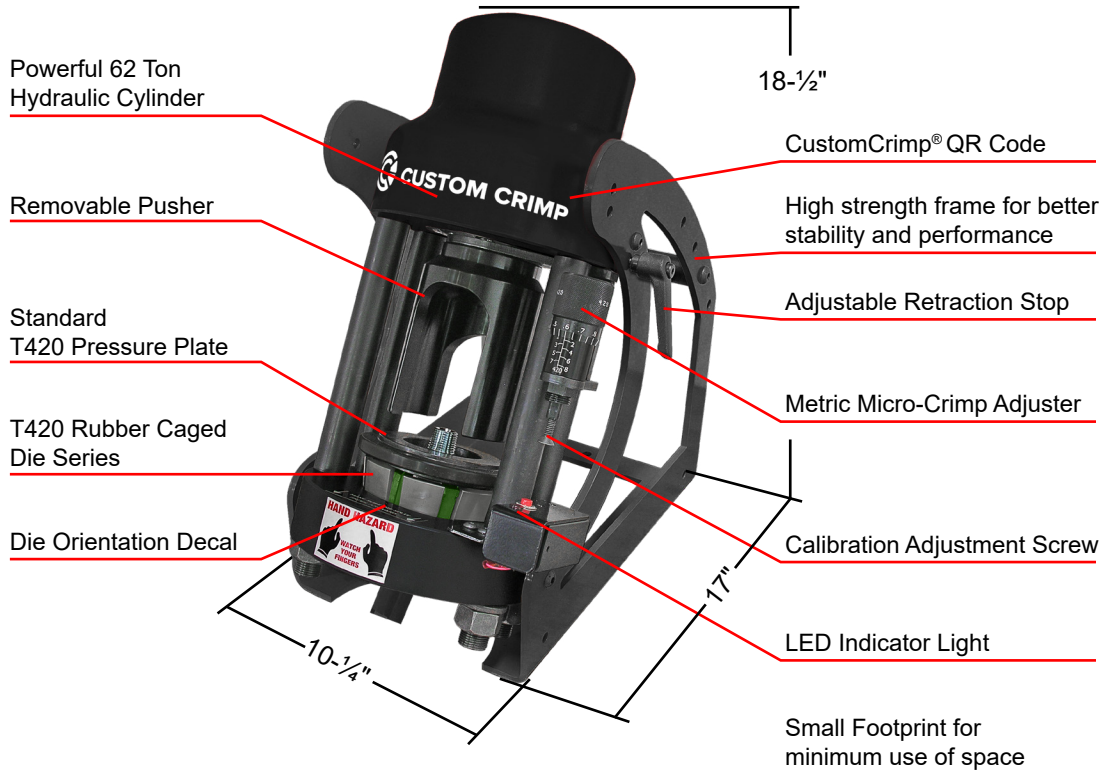

D160S-T420 Technical Specifications	
Crimping Force: 62 Ton	
Hydraulic Hose Capacity: 2 Wire = 1-1/4" 4 Spiral = 1-1/4" 6 Spiral = 1"	
Crimper Size: L: 17" x W: 10-1/4" x H: 18-1/2"	
Crimper Weight: 85 lbs	
Micrometer Style Adjustment: T420	
Die Series: T420 Rubber Caged	
Available ValPower® Pumps: Hand Pump (10,000 psi) Pneumatic Pump (10,000 psi) Electric Pump (1hp/110v)	

*Crimper capacity is estimated based on typical 1-piece fitting. Actual results may vary depending on the fitting and hose manufacturer.



CUSTOM CRIMP™

Innovating SMART Hose Assembly Solutions Since 1979

D160S-T420 PORTABLE SERIES CRIMPERS



D160-SH-T420 Portable Series Crimpers with ValPower® Hand Pump 10,000 psi

PERFORMANCE SPECIFICATIONS	
Pump Model	VHP-10-43
Reservoir Capacity	43 in ³ (705cc)
Weight	9 Lb (4.1 Kg)
Max Hydraulic Pressure	10,000 psi (680 bar)
Low Pressure Flow	.35 in ³ per stroke
High Pressure Flow	.07 in ³ per stroke
Maximum Handle Effort	65 Lb (30 Kg)



D160-SP-T420 Portable Series Crimpers with ValPower® Pneumatic Pump 10,000 psi

PERFORMANCE SPECIFICATIONS	
Pump Model	VAP-10-100
Reservoir Capacity	100 cu in (1,639 cc)
Weight	20 Lb (9 Kg)
Flow @ 0 psi	70 in ³ /min
Flow @ 5,000 psi	23 in ³ /min
Flow @ 10,000 psi	6 in ³ /min
Required air pressure @ 10,000 psi	85 psi



CUSTOM CRIMP™

Innovating SMART Hose Assembly Solutions Since 1979

FEATURES



D160S-T420 Series rugged steel frame and strain rods for strength, stability, performance, and durability for all service conditions of industrial use.



Open design, two piece rubber caged die set for heavy duty environments and removable pusher allows the operator to accurately position the fitting prior to crimping.



T420 Micrometer "Micro-Crimp Adjuster" is fully adjustable to make precise and repeatable crimps.



Built-in adjustable retraction stop limits ram retraction for quick repetitive crimps.



LED indicator light will turn on to indicate that the crimp is complete.



Easy calibration adjustment to increase or decrease crimp OD.



CUSTOM CRIMP™

Innovating **SMART** Hose Assembly Solutions Since 1979

INITIAL SET UP

FOLLOW THESE STEPS BEFORE YOU USE THE CRIMPER FOR THE FIRST TIME.

The D160S-T420 Portable Series hydraulic hose crimper paired with either a ValPower® Hand Pump, Pneumatic Pump or Electric Pump make the perfect combination for portable crimping requirements. Weighing only 85 lbs and mounted on a convenient carrying frame, this 62 tons of crimping force can be carried to almost any location where service is required.

- If the D160S-T420 series crimper is going to be used in the shop is recommended to mount the crimper on a sturdy workbench in a well-lit area. Workbench should be able to support the crimper, pump, and components weight.
- The crimper should be mounted close enough to the edge of the work surface so that hose will not contact the bench or work surface while crimping. There must be enough clearance for the hose to align perpendicular with the cone base, or the dies will not seat properly and the crimps will not be accurate.
- Manual Pump 10,000 psi, Pneumatic Pump 10,000 psi or Electric Pump 1HP motor 110V single phase 15 AMP, ValPower® offers rugged industrial duty hydraulic power units that will meet the demanding requirements of industrial users. Both manual and air pumps have aluminum reservoirs and all electric models have steel reservoirs to withstand the temperature and service conditions of industrial use.
- A 10,000 psi hose and quick disconnect fitting has been included with the crimper to connect to any of the optional power units to the D160S-T420 cylinder port.

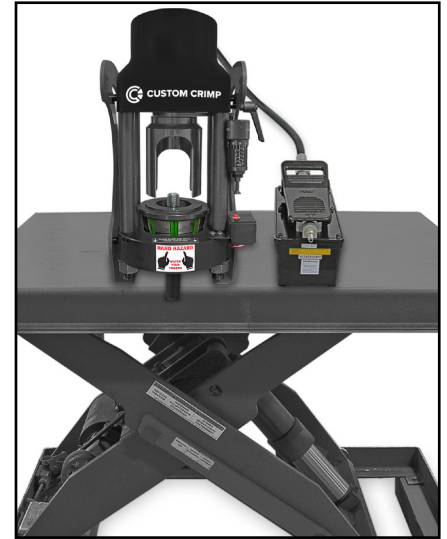



CUSTOM CRIMP™

Innovating SMART Hose Assembly Solutions Since 1979

LUBRICATION PROCEDURE

Grease Point # 1

Place a thin layer of CrimpX oil (supplied with crimper) or a high pressure molybdenum high pressure grease on the surface of the cone base. (as shown in photo # 1).



Photo # 1

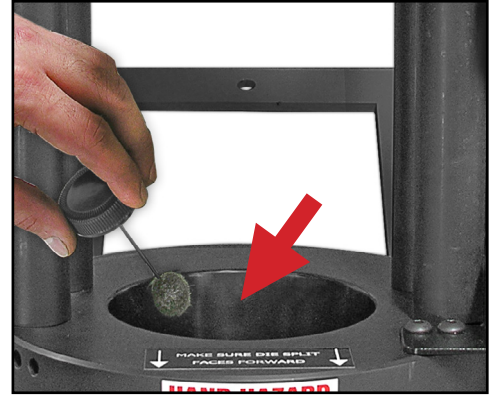

Grease Point # 2

Before sliding the standard pressure plate or the notched pressure plate over the correct dies, place a thin layer of CrimpX oil (supplied with crimper) or a high pressure molybdenum high pressure grease on the entire area that dies come in contact with (as shown in photo # 2).

Photo # 2

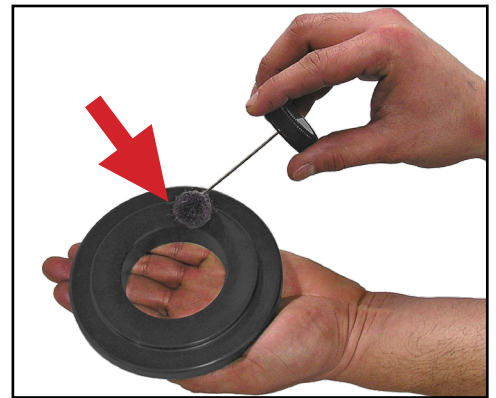

Notched Pressure Plate:

For use with 90 degree fitting only.

If Dies are sticking in the surface of the cone base:

Continue to lubricate / grease as explained above in addition to lubricating each die finger individually. (as shown in photo # 3).

Note: The die fingers must be lubricated at both positions that come in contact with the pressure plate and the cone base.

Note: Lubrication is not required before each crimp. Typical lubrication is after 100 crimps.

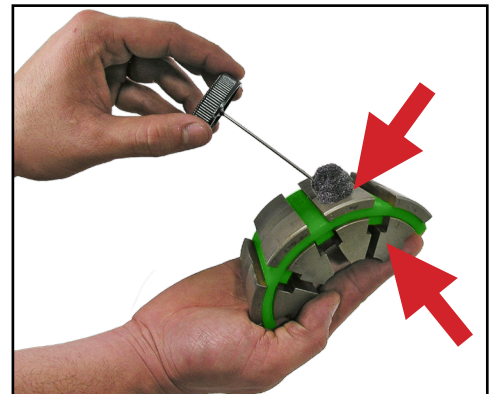
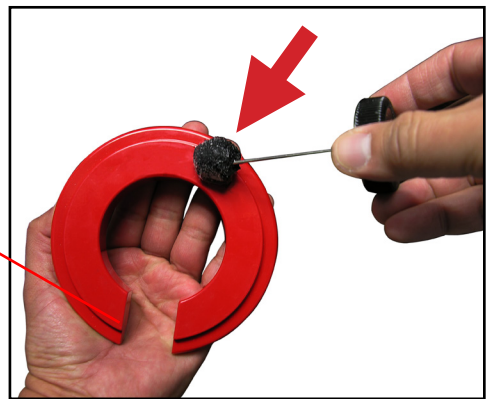

Photo # 3



CUSTOM CRIMP™

Innovating SMART Hose Assembly Solutions Since 1979

CRIMPING WITH STANDARD T420 PRESSURE PLATE

Note: Follow the lubrication procedure prior to crimping procedure.

CAUTION: Failure to lubricate the die set and pressure plate could result in the die seizing in the cone base.

Step 1: Make certain that the **Cone Base** is clean and lubricated prior to inserting the die set.



Step 2: Select the **Correct Die Set** for the combination of hose and fitting being crimped.

Note: Consult your hose and fitting manufacturer for the correct die size for the combination of hose and fitting being crimped.

Note: The number etched on the OD of the die ring represents the fully closed diameter of the die set in millimeters. In addition, the rubber caged die sets are color-coded for easier identification.



Step 3: **Lubricate the contact surfaces**, both top and outside edges of the die fingers, with CrimpX oil (supplied with crimper) or a high pressure molybdenum high pressure grease.

Failure to lubricate the contact surfaces with the correct lubricant will cause the dies to seize in the cone base, causing damage to the die set as well as possibly damaging the crimper.

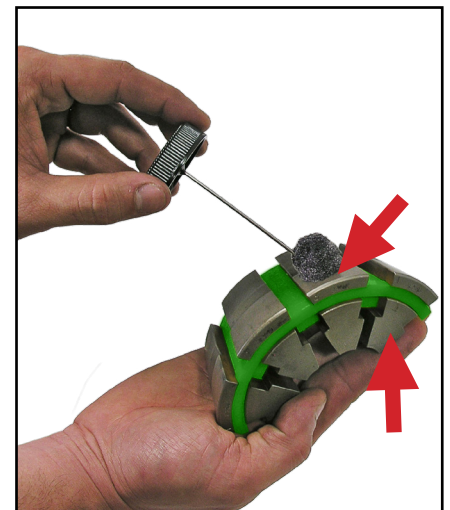



CUSTOM CRIMP™

Innovating SMART Hose Assembly Solutions Since 1979

CRIMPING WITH STANDARD T420 PRESSURE PLATE

Step 4: Place the **Lubricated Die Set** squarely in the cone base.

Note: Make sure the split of the die cages is facing the operator.
(as shown).



Step 5: Align the fitting in the die set according to the hose and fitting manufacturer's recommendation.

Note: Compress the die set by hand to hold the hose and fitting in place.



Step 6: Place the **Lubricated Standard Pressure Plate** over the die set.





CUSTOM CRIMP™

Innovating SMART Hose Assembly Solutions Since 1979

CRIMPING WITH STANDARD T420 PRESSURE PLATE

Step 7: Slide the **Pusher** onto the pusher retaining ring on the hydraulic cylinder.

Note: Make sure slot in pusher goes over lip on pusher retaining ring.

CAUTION: Damage to pusher and retaining ring can occur if misaligned.

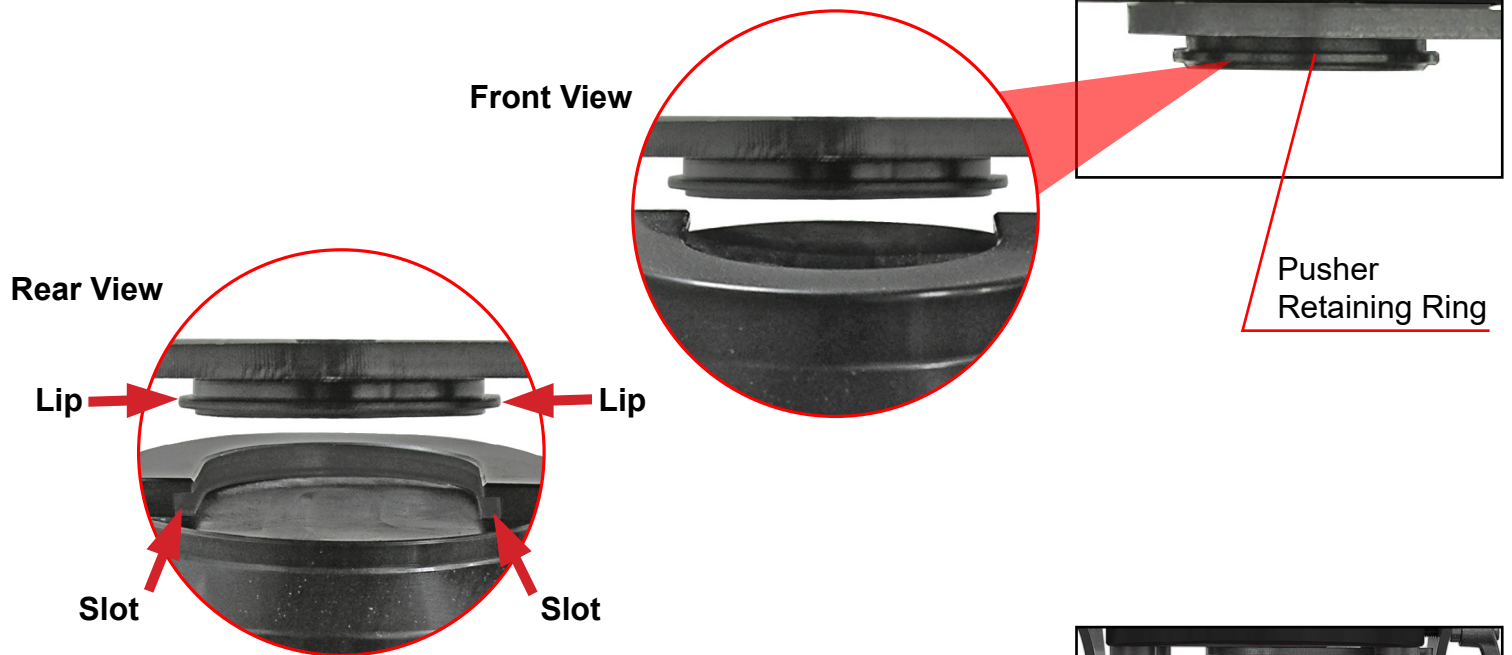

Note: Make sure the pusher is positioned correctly as shown.





CUSTOM CRIMP™

Innovating SMART Hose Assembly Solutions Since 1979

CRIMPING WITH STANDARD T420 PRESSURE PLATE

Step 8: Set the Micro-Crimp Adjuster to the setting recommended by the hose and fitting manufacturer for the combination of hose and fitting being crimped.

For example: With a 23mm die set and the Micro-Crimp Adjuster set at 3.0, the finished crimp diameter would be 26.0 mm (23mm + 3.0mm).

Note: Each die set has a limited range of diameters for which a satisfactory crimp can be obtained. Always consult your hose and fitting manufacturer for the correct die set for the hose and fitting being crimped.

Step 9: Apply pressure to the (Hand or Pneumatic Pump), to bring the pusher in contact with the compression ring until the hose and fitting are held in position with very light pressure.

- Check to make sure the standard pressure plate is evenly placed on the die set and the die set is correctly aligned.
- Recheck the fitting for alignment.

Step 10: Continue to apply pressure as pusher travels downward, compressing the standard pressure plate onto the die set to crimp the coupling.

As the micrometer moves down, it will touch the red button and the LED indicator light will turn on to indicate that the crimp is complete.

Release pressure so the pusher will retract.





CUSTOM CRIMP™

Innovating SMART Hose Assembly Solutions Since 1979

CRIMPING WITH STANDARD T420 PRESSURE PLATE

Step 11: Check the final crimp diameter with calipers to confirm that it is within manufacturer's specifications.

Note: Always consult with your hose and fitting manufacturer to obtain the most current crimp specifications.

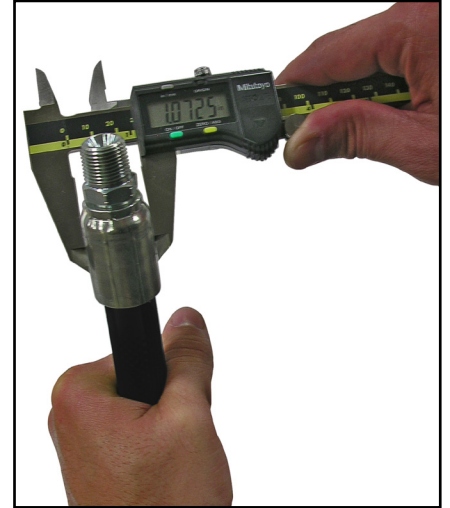



CUSTOM CRIMP™

Innovating SMART Hose Assembly Solutions Since 1979

CRIMPING WITH NOTCHED T420 PRESSURE PLATE

WHEN USING THE NOTCHED T420 PRESSURE PLATE, FOR USE WITH 90 DEGREE FITTING ONLY, FOLLOW THESE PROCEDURES:

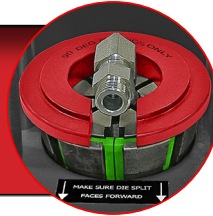

Note: Follow the lubrication procedure prior to crimping procedure.

CAUTION: Failure to lubricate the die set and pressure plate could result in the die seizing in the cone base.

Step 1: Make certain that the **Cone Base** is clean and lubricated prior to inserting the die set.



Step 2: Select the **Correct Die Set** for the combination of hose and fitting being crimped.

Note: Consult your hose and fitting manufacturer for the correct die size for the combination of hose and fitting being crimped.

Note: The number etched on the OD of the die ring represents the fully closed diameter of the die set in millimeters. In addition, the rubber caged die sets are color-coded for easier identification.

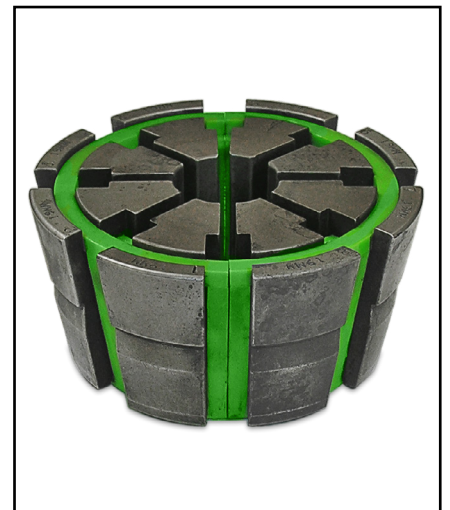

Step 3: **Lubricate the contact surfaces**, both top and outside edges of the die fingers, with CrimpX oil (supplied with crimper) or a high pressure molybdenum high pressure grease.

Failure to lubricate the contact surfaces with the correct lubricant will cause the dies to seize in the cone base, causing damage to the die set as well as possibly damaging the crimper.

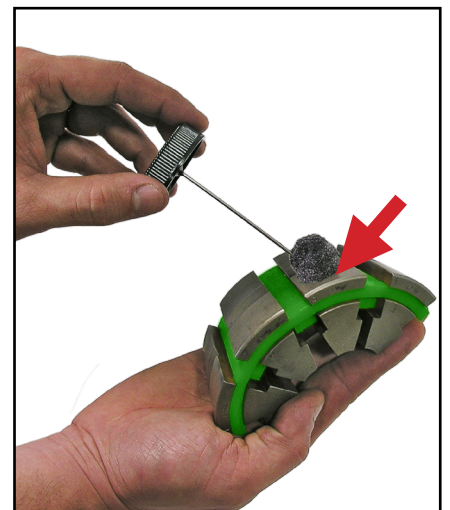



CUSTOM CRIMP™

Innovating SMART Hose Assembly Solutions Since 1979

CRIMPING WITH **NOTCHED** T420 PRESSURE PLATE

Step 2: Place the **Lubricated Die Set** squarely in the cone base.

Note: Make sure the split of the die cages is facing the operator. (as shown).



Step 5: Align the **90 degree fitting** in the die set according to the hose and fitting manufacturer's recommendation.

Note: Compress the die set by hand to hold the hose and fitting in place.



Step 6: Place the **Lubricated Notched Pressure Plate** over the die set.

Note: The notched pressure plate **MUST** be covering all 8 die fingers as shown.

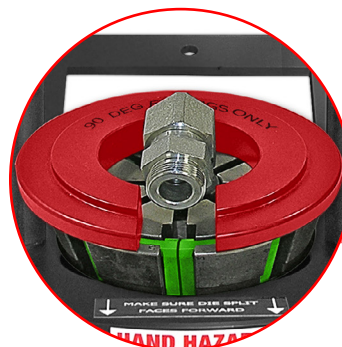



CUSTOM CRIMP™

Innovating SMART Hose Assembly Solutions Since 1979

CRIMPING WITH NOTCHED T420 PRESSURE PLATE

Step 7: CAUTION: DO NOT MISALIGN NOTCHED PRESSURE PLATE OR DAMAGE WILL OCCUR.

Note: You MUST follow these steps when crimping with the notched pressure plate.

A. Die split must face the operator.

B. Notched Pressure Plate MUST cover all 8 die fingers.

Damage can occur to die fingers if the parts aren't aligned properly.



Wrong Alignment



Broken Die Finger



Step 8: After placing the notched pressure plate covering all 8 die fingers as shown, slide the **Pusher** onto the pusher retaining ring on the hydraulic cylinder.

Note: Make sure slot in pusher goes over lip on pusher retaining ring. Refer to page 13 for details if needed.

CAUTION: Damage to the pusher and retaining ring can occur if they are misaligned.

Note: Recheck that the notched pressure plate is covering all 8 die fingers.





CUSTOM CRIMP™

Innovating SMART Hose Assembly Solutions Since 1979

CRIMPING WITH NOTCHED T420 PRESSURE PLATE

Step 8: Set the Micro-Crimp Adjuster to the setting recommended by the hose and fitting manufacturer for the combination of hose and fitting being crimped.

For example: With a 23mm die set and the Micro-Crimp Adjuster set at 3.0, the finished crimp diameter would be 26.0 mm (23mm + 3.0mm).

Note: Each die set has a limited range of diameters for which a satisfactory crimp can be obtained. Always consult your hose and fitting manufacturer for the correct die set for the hose and fitting being crimped.

Step 9: Apply pressure to the (Hand or Pneumatic Pump), to bring the pusher in contact with the compression ring until the hose and fitting are held in position with very light pressure.

- Check to make sure the notched compression ring is evenly placed on the die set and the die set is correctly aligned.
- Recheck the fitting for alignment.

Step 10: Continue to apply pressure as pusher travels downward, compressing the compression ring onto the die set to crimp the coupling.

As the micrometer moves down, it will touch the red button and the LED indicator light will turn on to indicate that the crimp is complete.

Release pressure so the pusher will retract.





CUSTOM CRIMP™

Innovating SMART Hose Assembly Solutions Since 1979

CRIMPING WITH **NOTCHED** T420 PRESSURE PLATE

Step 11: Check the final crimp diameter with calipers to confirm that it is within manufacturer's specifications.

Note: Always consult with your hose and fitting manufacturer to obtain the most current crimp specifications.

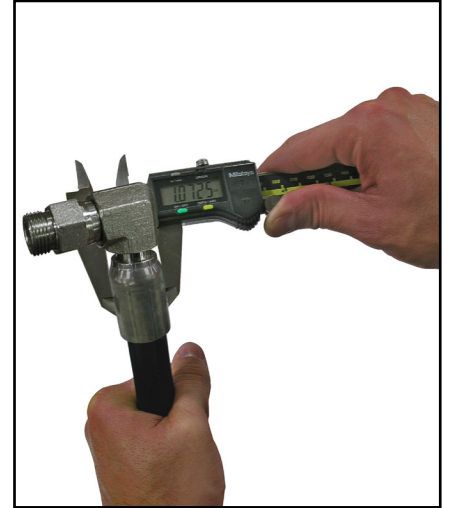



CUSTOM CRIMP™

Innovating SMART Hose Assembly Solutions Since 1979

CALIBRATION CHECK PROCEDURE

THE CRIMPER IS CALIBRATED PRIOR TO SHIPMENT, BUT A CALIBRATION CHECK IS RECOMMENDED PRIOR TO USING THE CRIMPER FOR THE FIRST TIME.

Note: Follow the lubrication procedure prior to calibration check.

CAUTION: Failure to lubricate the die set and pressure plate could result in the die seizing in the cone base.

Step 1: Make certain that the **Cone Base** is clean and lubricated prior to inserting the die set.

Step 2: Place **Any Lubricated Die Set** squarely in the cone base.

Note: Make sure the split of the die cages is facing the operator. (as shown).



Step 3: Place the **Lubricated Pressure Plate** over the die set.

Note: A hose and fitting are not required for a calibration check.





CUSTOM CRIMP™

Innovating SMART Hose Assembly Solutions Since 1979

CALIBRATION CHECK PROCEDURE

Step 4: Slide the **Pusher** onto the pusher retaining ring on the hydraulic cylinder.

Note: Make sure slot in pusher goes over lip on pusher retaining ring
Refer to page 11 for details if needed.

CAUTION: Damage to the pusher and retaining ring can occur if they are misaligned.



Step 5: Set the **T420 Micro-Crimp Adjuster** to “0”.



Step 6: Apply pressure to the (Hand or Pneumatic Pump), to bring the pusher in contact with the compression ring.





CALIBRATION CHECK PROCEDURE

Step 7: Continue to apply pressure, If the ram extends, the dies are completely closed, the micrometer touched the red button, and the LED indicator light is turned on as shown, the crimper is correctly calibrated. Release pressure so the pusher will retract.

Note: If the LED Indicator Light becomes faint, replace the (2) AA batteries as needed.

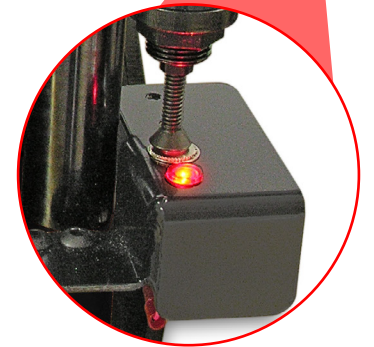

Step 7: If the above conditions are not met, the crimper requires recalibration, hold the micrometer barrel with a 5/16 inch open end wrench and rotate the stem either in or out with a 5/32 inch hex key wrench.

Note: 1/4 turn of screw will change crimp diameter approximately 0.008".

- Rotating the stem out of the barrel decreases the time required for the pump to shut off.
- Recheck calibration.





CUSTOM CRIMP™

Innovating SMART Hose Assembly Solutions Since 1979

INCLUDED ACCESSORIES



T420 Micrometer
P/N:103085



Pusher P/N:100825



Standard T420 Pressure Plate
P/N:103270



Die Removal Magnet
P/N:104679



CRIMPX Die Lubricant Oil:
4 oz bottle with dauber cap
P/N:103886



3/8 Quick Disconnect
Female Installed



10,000 psi Hose Assembly
W/ 3/8 Quick Connect
Male Tip



CUSTOM CRIMP™

Innovating SMART Hose Assembly Solutions Since 1979

AVAILABLE ACCESSORIES



ValPower®
Hand Pump 10,000 psi
P/N:VHP-10-43



ValPower®
Pneumatic Pump 10,000 psi
P/N:VAP-10-100



ValPower®
Multi-Electric Pump



Notched Pressure Plate
P/N:104662



D-Series Drawer Assembly/Stand
P/N:104650-Black



D165 Coupling Stop
P/N:100954



T420 Rubber Die Cages
[Refer to page 27 for more details](#)



CustomCrimp® Notched Digital
Caliper IN/MM P/N:CC-Caliper



CRIMPX Die Lubricant:
Grease 4 oz can with brush
P/N:104162



TROUBLESHOOTING

PROBLEM: THE CRIMPER WILL NOT RUN AT ALL

- The white rocker switch is also a circuit breaker. Check to see that the circuit breaker has not been tripped.
- Check the wall outlet. The crimper comes from the factory wired for a 115 volt single phase circuit. Use of extension cords or outlets with inadequate power can damage the motor. Do not run the crimper from a portable power source.
- Check the stop switch mounted to the switch bracket under the Micro-Crimp Adjuster. This is a normally closed switch and if it does not close the crimper will not operate.
CAUTION: Do not operate the crimper with this switch jumpered as the pump will not shut off and the brackets can be damaged.
- Check the pneumatically actuated switch in the electrical box mounted on the motor. This switch controls power to the motor and is actuated with air pressure from the pendant switch bulb.

PROBLEM: THE CRIMP DIAMETER IS TOO LARGE

- Incorrect setting of the Micro-Crimp Adjuster. Check crimp specifications.
(NOTE: All published machine settings are approximate. To correct for slight variances, the gauge settings may need to be adjusted for the specific hose, fitting and size combination).
- Incorrect die being used. Each die has a useable range of approximately 3mm (.120 in) above the closed diameter of the die. The closed diameter is the die size stamped on the die ring.
- Check crimper calibration and re-calibrate if required.
- Inadequate pump pressure. Check oil level in the pump. It should be 1-1/2 to 2 inches below the fill plug.
- Replenish with ISO Viscosity Grade 46 hydraulic oil.
- Inadequate lubrication of the dies and compression ring causing the pump to work harder than normal to reach the required diameter. Use only the crimpx oil / grease shipped with the machine or a high pressure molybdenum high pressure grease (equivalent).
- Inadequate pressure being generated by the pump. This is most likely if the crimper can crimp the smaller size hoses and not the larger hoses. When correctly adjusted, the pump should generate approximately 10,000 psi.
Do Not adjust pump to produce in excess of 10,000 psi as damage to components or personal injury may result.
- No pressure being generated by the pump. There should be a definite change in pitch of the pump as it cycles into high pressure mode and begins to “work” harder.

PROBLEM: THE CRIMP DIAMETER IS TOO SMALL

- Incorrect setting of the Micro-Crimp Adjuster. Check crimp specifications.
(NOTE: All published machine settings are approximate. To correct for slight variances, the gauge settings may be adjusted for the specific hose, fitting and size combination).
- Incorrect die being used (See die range under Crimp Diameter Too Large).
- Check crimp diameter and re-calibrate if necessary.

PROBLEM: THE DIES STICKING IN THE CONE BASE

- Inadequate lubrication of the compression ring and die surfaces. Use only the crimpx oil / grease shipped with the machine or a high pressure molybdenum high pressure grease (equivalent).
- Refer to D165 Lubrication Procedure for more details.



CUSTOM CRIMP™

Innovating SMART Hose Assembly Solutions Since 1979

COMPONENT PARTS BREAKDOWN

T420 SERIES DIE PARTS (AI-102254)			
ITEM	PART NUMBER	DESCRIPTION	QTY
1	102997-XX	CUSTOM CRIMP DIE CAGE	2
2	VARIES WITH THE DIE SIZE	8 PC DIE FINGER SET	8

CUSTOM CRIMP DIE CAGE HALF T420 SERIES	
PART NUMBER	DESCRIPTION
102997-BLACK	T420 CUSTOM CRIMP DIE CAGE HALF-BLACK
102997-BLUE	T420 CUSTOM CRIMP DIE CAGE HALF-BLUE
102997-BROWN	T420 CUSTOM CRIMP DIE CAGE HALF-BROWN
102997-GREEN	T420 CUSTOM CRIMP DIE CAGE HALF-GREEN
102997-ORANGE	T420 CUSTOM CRIMP DIE CAGE HALF-ORANGE
102997-SILVER	T420 CUSTOM CRIMP DIE CAGE HALF-SILVER
102997-RED	T420 CUSTOM CRIMP DIE CAGE HALF-RED
102997-YELLOW	T420 CUSTOM CRIMP DIE CAGE HALF-YELLOW
102997-PURPLE	T420 CUSTOM CRIMP DIE CAGE HALF-PURPLE

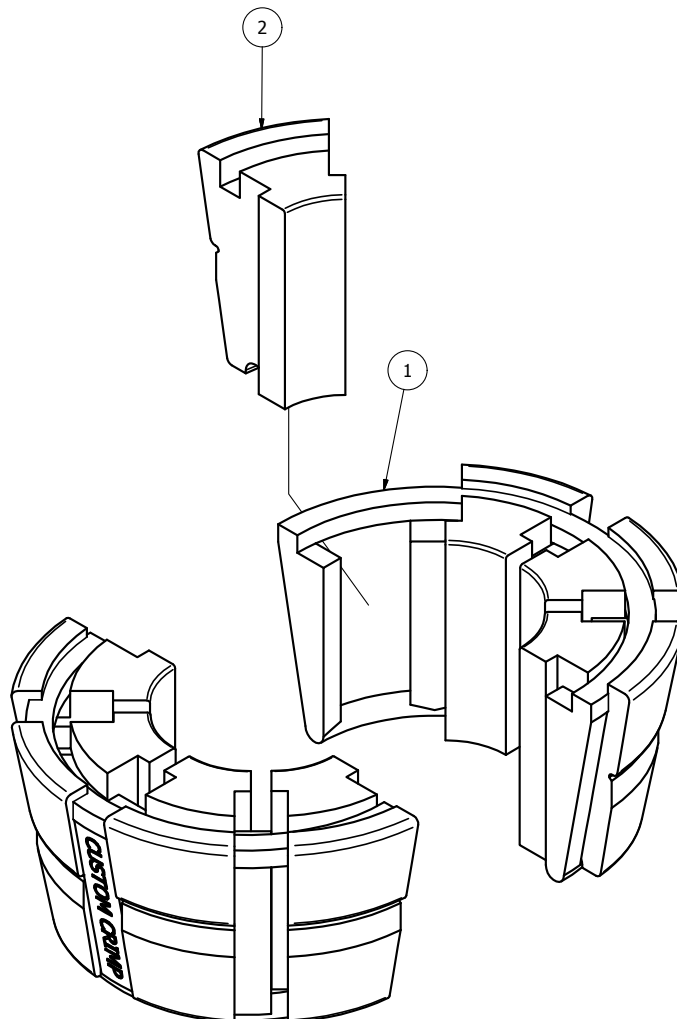



COMPONENT PARTS BREAKDOWN

60 Ton Cylinder / Top Flange Assembly (102219)			
Item	Part Number	Description	Qty
1	102158	60 Ton Body / Top Flange	1
2	100651	60 Ton Piston	1
3	227-9250	227 Disogrin O-Ring	1
4	101106	Piston End Cap	1
6	100760_12	60 Ton Spring	1
7	102287	Spring Plug	1
8	210D90	210 Disogrin O-Ring	1
9	F1-POM-3.75X4.00X0.375	3.75 x 4.00 x 0.375 Wear Ring	2
10	POLYPAK 4 x 3-1/2 x 3/8	3.50 x 4.00 x 0.375 Polypak	1
11	90108A417	3/8 Flat Washer	1
12	91251A632	3/8-16 x 2 SHCS	1
13	SH940-35	375 Ram Wiper	1
14	102169	60 Ton Retaining Ring	1
15	91251A424	3/8-24 X 1" SHCS	6

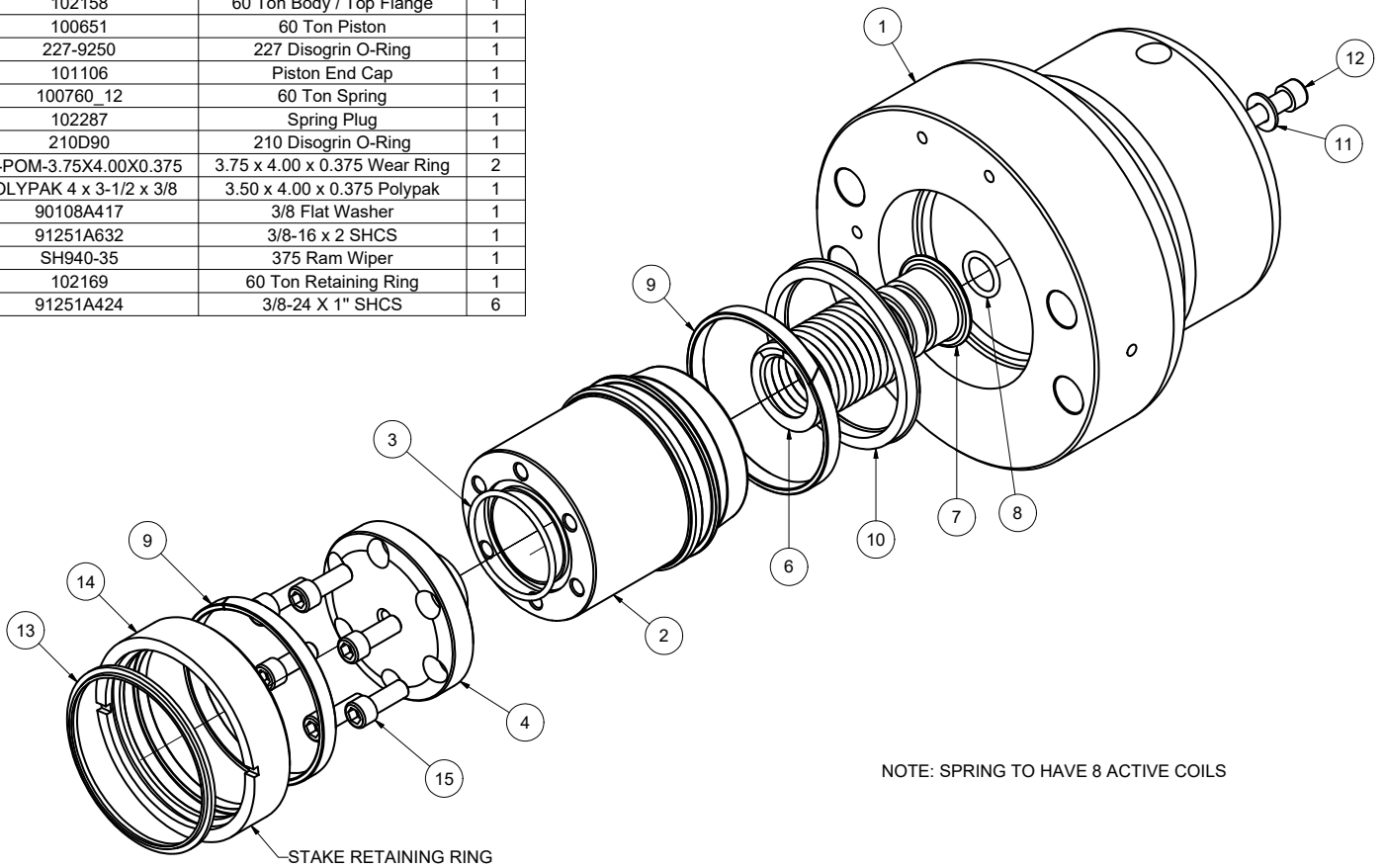



COMPONENT PARTS BREAKDOWN

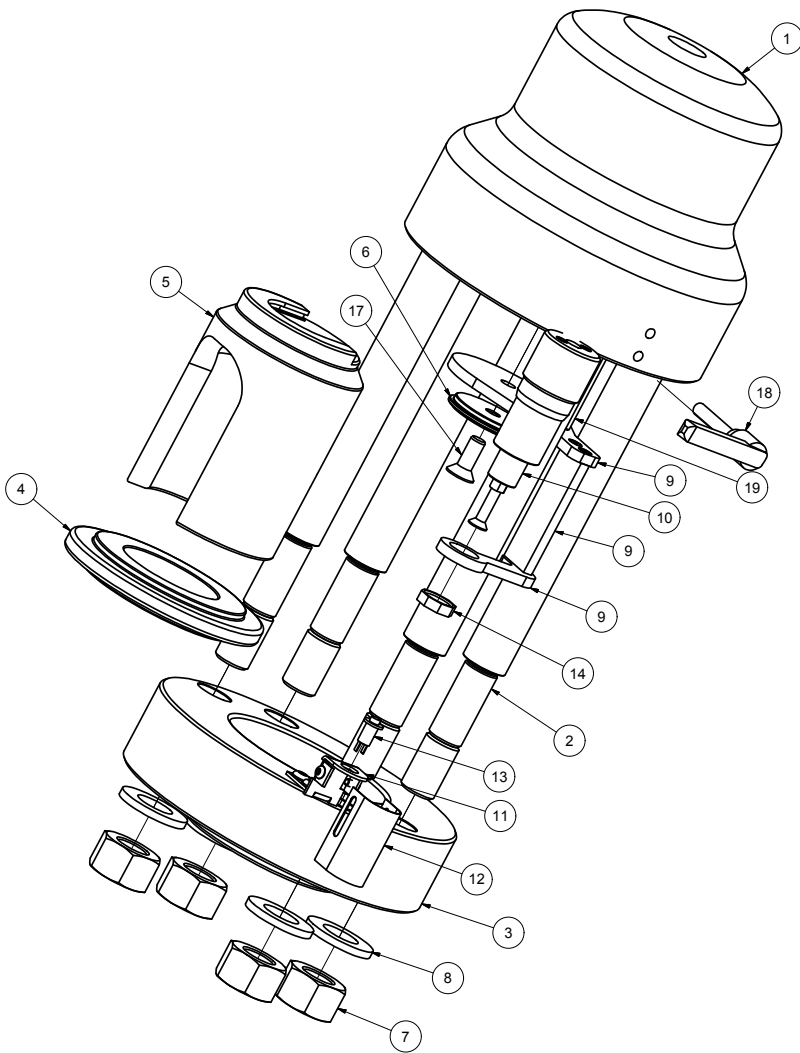

D165 - T420 Crimper Sub Assembly			
ITEM	PART NUMBER	DESCRIPTION	QTY
1	102219	D165 60 Ton Cylinder Assembly	1
2	102270	8 1/4" Strain Rod	4
3	104727	D165 - T420 Base Flange	1
4	103270	D165 - T420 Press Plate	1
5	100825	60 Ton Pusher	1
6	100812	Pusher Retaining Pin	1
7	90499A845	7/8-14 Hex Nut	4
8	11038	7/8 Narrow Rim Washer	4
9	102220-T420	Micrometer Holding Assembly	1
10	100628	Standard Micrometer Assembly ★	1
11	101092	Limit Switch Bracket ★	1
12	100692	Limit Switch Guard ★	1
13	903 Switch	Red Limit Switch ★	1
14	100727	Micrometer Nut	1
18	KHA-126	Stop Rod Locking Handle	1
19	102224	Retraction Stop Rod	1

*Only available for D165-T420 Series Crimpers.



COMPONENT PARTS BREAKDOWN

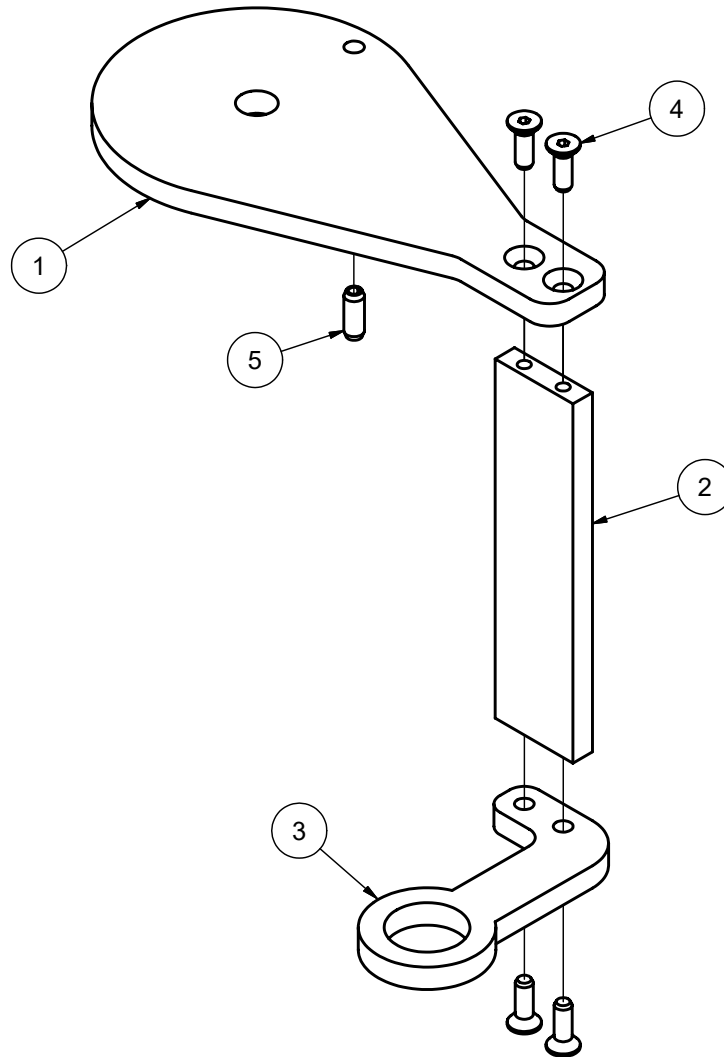

D165 Micrometer Mount Assembly (102220)			
Item	Part Number	Description	Qty
1	102214	Micrometer Suspension Flange	1
2	102217	Micrometer Brace	1
3	102215	Micrometer Base Bracket	1
4	91253A194	8-32 x 1/2 HSFHCS	4
5	98296A245	3/16 Dia. x 1/2 Spring Pin	1



CUSTOM CRIMP™

Innovating SMART Hose Assembly Solutions Since 1979

CUSTOMCRIMP® “NO-NONSENSE” WARRANTY STATEMENT

All Custom Crimp® Products are warranted to be free of defects in workmanship and materials for one year from the date of installation. This warranty ends when the product becomes unusable for reasons other than defects in workmanship or material.

Any Custom Crimp® Product proven to be defective in workmanship or material will be repaired or replaced at no charge. To obtain benefits of this warranty, first, contact Warranty Repair Department at Custom Machining Services at **(219) 462-6128** and then deliver via prepaid transportation the complete hydraulic product to:

**ATTN: WARRANTY REPAIR DEPT.
Custom Machining Services, Inc.
318 North Co. Rd 400 East
Valparaiso IN 46383**

If any product or part manufactured by Custom Crimp® is found to be defective by Custom Crimp®, at its option, Custom Crimp® will either repair or replace the defective part or product and return via ground transportation, freight prepaid.

Custom Crimp® will not cover any incoming or outgoing freight charges for machines sold outside The United States.

This warranty does not cover any product or part which is worn out, abused, altered, used for a purpose other than for which it was intended, or used in a manner which was inconsistent with any instructions regarding its use.

Electric motors are separately warranted by their manufacturer under the conditions stated in their separate warranty.

CRIMP

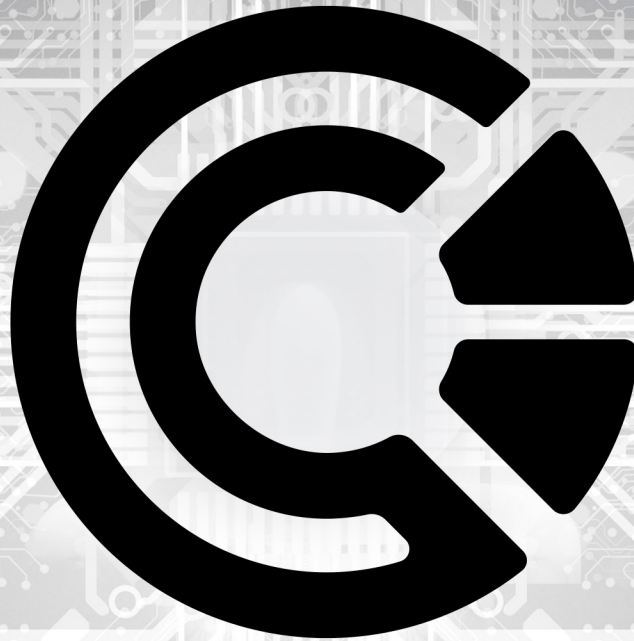

CUT

TEST

CUSTOM CRIMP®, YOUR SINGLE SOURCE FOR HOSE ASSEMBLY PRODUCTS.

CUSTOM CRIMP® | Custom Machining Services, Inc.
326 North 400 East Valparaiso, IN 46383



Visit us at: www.customcrimp.com



For sales: ccsales@customcrimp.us



For support: ccsupport@customcrimp.us



Custom Crimp®

Innovating **SMART** Hose Assembly Solutions Since 1979

www.customcrimp.com

(219) 462-6128

