



D305 SERIES HYDRAULIC HOSE CRIMPER OPERATORS MANUAL

MODELS COVERED:

The D305 Crimper comes with with both a standard and metric micrometer. (See conversion note in Quick Start Guide)

230 Volt Single Phase and 230 Volt 3 Phase motors are available.



SAFETY PRECAUTIONS



READ INSTRUCTIONS AND IDENTIFY ALL COMPONENT PARTS BEFORE USING CRIMPER.

CRIMPER CAN PRODUCE 110 TONS OF FORCE. KEEP BOTH HANDS AWAY FROM PINCH POINTS.

CONSULT HOSE AND FITTING MANUFACTURER'S SPECIFICATIONS FOR CORRECT MACHINE SETTINGS AND CRIMP MEASUREMENTS.

ALWAYS WEAR EYE PROTECTION.

**For Parts and Service, Contact:
Custom Machining Services, Inc.
Valparaiso, In 46383
(219) 462-6128**

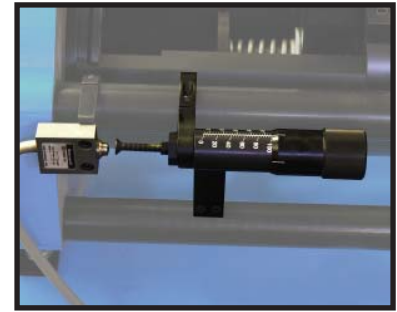

MICRO CRIMP ADJUSTER



RETRACTION STOP ADJUSTER



STANDARD D305 DIE SET

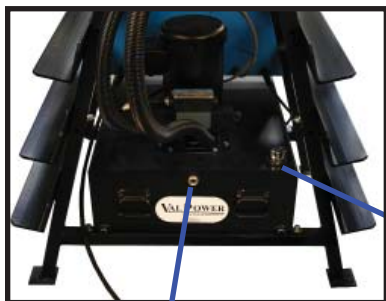

RESERVOIR SIGHT GLASS.
OIL LEVEL SHOULD BE IN THE MIDDLE OF SIGHT GLASS WHEN PUSHER IS IN THE FULLY RETRACTED POSITION. DO NOT OVERFILL OR EXCESSIVE OIL SEAPAGE WILL OCCUR IN USE.

STANDARD MICROMETER



METRIC MICROMETER



FILL & VENT CAP.
BE SURE CAP IS VENTING PROPERLY OR EXCESSIVE OIL SEAPAGE WILL OCCUR IN USE.

Die Series(1)	D305
Maximum Cylinder Force	110 Ton
Maximum Hose Diameter (2 Wire)	2"
Maximum Hose Diameter (4 Wire)	2"
Maximum Hose Diameter (6 Wire)	2"
Crimper Depth	36"
Crimper Width	36"
Crimper Height	53"
Weight	850 Lb
Pump	Electric
Maximum Pump Pressure	10,000 psi
Pump HP	3 HP
Reservoir Capacity	15 Gal
Oil Type	ISO Viscosity Grade 46
Electric Power Requirement (Std)	220V 1 Ph
Electric Power Requirement (Optional)	220V 3Ph
Approx Crimps per Hour(2)	900

- (1) Dies interchange with Dayco® NP 100 Series Dies
- (2) Based upon -8 100R2AT hose with 1 pc style fitting



D305 CRIMPER QUICK START GUIDE

- Position the crimper in a well lit area with adequate room to work on all sides.
- Confirm that the power source of the crimper matches the voltage shown above the Power Switch on the front panel. The crimper comes wired for one of the following:
 - 230 Volt Single Phase Current
 - 230 Volt 3 Phase Current
 - 460 Volt 3 Phase Current
- **The crimper comes calibrated from the factory. Prior to crimping a calibration check should be run to assure accurate crimps.**

- The D305 Crimper can be converted from standard to metric settings by loosening the jam nut on the Micro Crimp Adjuster and rotating the barrel 180 degrees.



- To check calibration:
 - Set the Standard Micrometer at "95"
 - Set the Metric Micrometer at "0"



- Lubricate the compression cone and the contact surfaces of the die. Use a high pressure moly type grease only.

- With the Manual/Auto switch in Manual, place any D305 Series die in the crimper.

- Press and hold Advance on the foot switch.

- The dies should come to a complete close before the crimper shuts off.

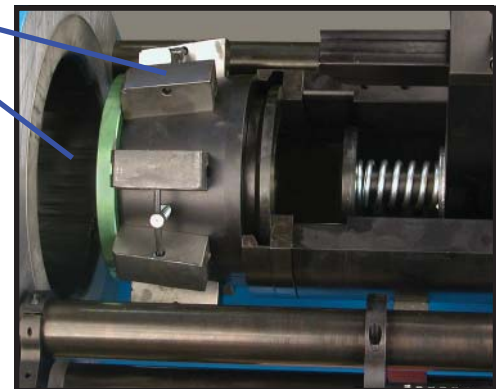

- **If the die fingers do not completely close before the crimper shuts off or if the crimper continues to run after the dies are completely closed, recalibrate as follows:**

- If the crimper shuts off before the die fingers are completely closed, hold the stem of the Micro Crimp Adjuster and turn the threaded extension screw in slightly until the crimper shuts off just as the die fingers are completely closed.

- If the crimper continues to run after the die fingers are completely closed, hold the Micro Crimp Adjuster stem and turn the extension screw out slightly until the crimper shuts off just as the die fingers are completely closed.

CRIMPING PROCEDURE

- Select the proper die size for the combination of hose and fitting. Refer to the hose and fitting manufacturer's specifications to determine the required die size.

Each die set has a limited range for which an effective crimp can be obtained.

The number shown on the die ring represents the closed or minimum crimp diameter for that die set.

As a "rule of thumb" a die set can crimp from the minimum diameter shown on the die ring to 4mm (0.16 inches) larger.

Always consult the hose and fitting manufacturer's recommendations.

- Insert the lower half of the die set in the die retention slot on the pusher as shown.
- Insert the hose and fitting in the die set such that the crimp will be at the correct position and bring the coupling stop in contact with the fitting.

Hint: Set the Coupling Stop so that the end of the crimped section of the fitting aligns with the end of the Coupling Stop as shown. When the hose is inserted in the crimper the Coupling stop will be correctly positioned.

- Set the Micro-Crimp adjuster at the correct setting.
Note: The metric Micro-Crimp adjuster is a direct reading micrometer. For example: With a 35mm die set and the Micro-Crimp adjuster set at "3.0", the final crimp diameter would be 38mm. (35 + 3).

- Place the top half of the die set in the pusher
Dies and cone must have a light coat of high-pressure moly grease.

- Insert the hose and fitting through the front of the machine against the coupling stop.

- Press and hold advance on the foot switch until the crimper shuts off.

When the switch is in the Auto position, press Advance to start the cycle, and the crimper will complete the crimp cycle and retract to the preset position.

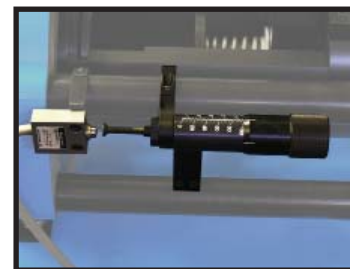
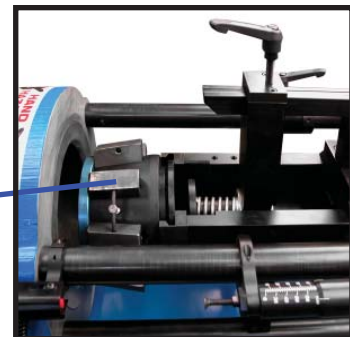
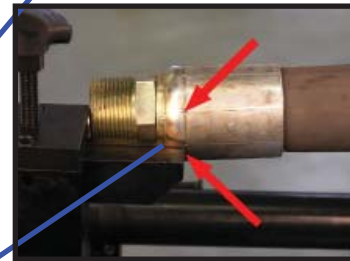
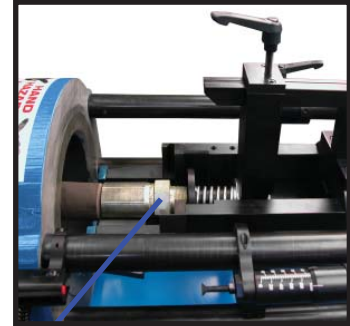

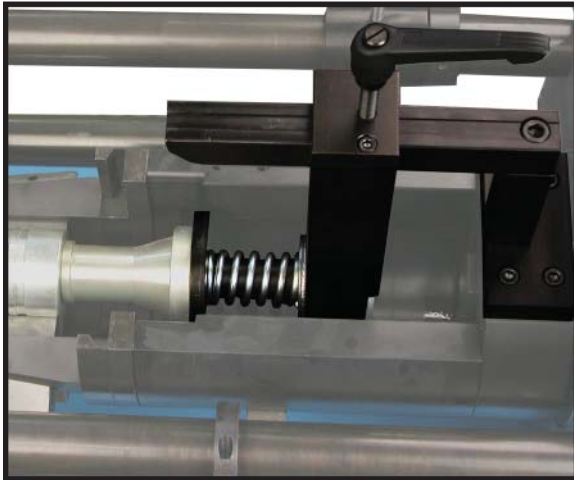

The adjustable retraction stop limits the cylinder retraction to speed up multiple crimping operations. Adjust the retraction stop to allow the die set to open up enough to allow easy removal of the fitting.

The adjustable coupling stop provides a convenient method to accurately repeat settings when crimping multiple fittings of the same type.

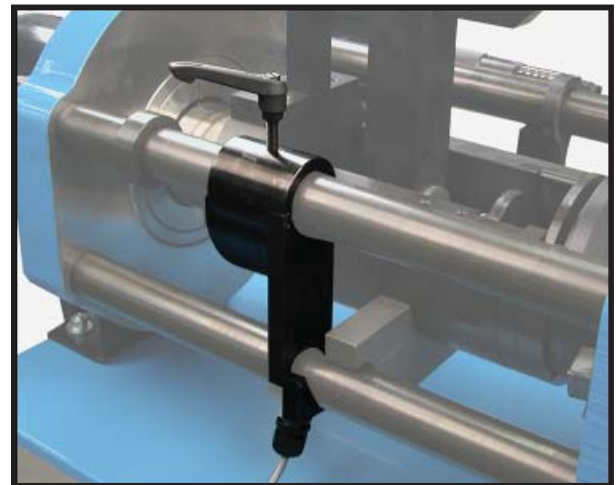

The Auto/Manual switch permits fully automatic advance and retraction. When the switch is in Auto, press Advance on the foot switch and the crimper will complete the crimp cycle and automatically retract to the preset retraction position. Set the retraction stop in the manual mode. When the switch is in Manual, the operator has complete control of the cylinder position with the Advance/Retract foot switch

Caution: When the unit is in Auto mode the cycle will resume immediately after release of the Emergency Stop Button.

“Standard” and Metric micrometer settings are etched on opposite sides of the micrometer barrel. To convert the crimper from “Standard” to metric settings, loosen the jam nut and rotate the micrometer barrel 180 degrees.



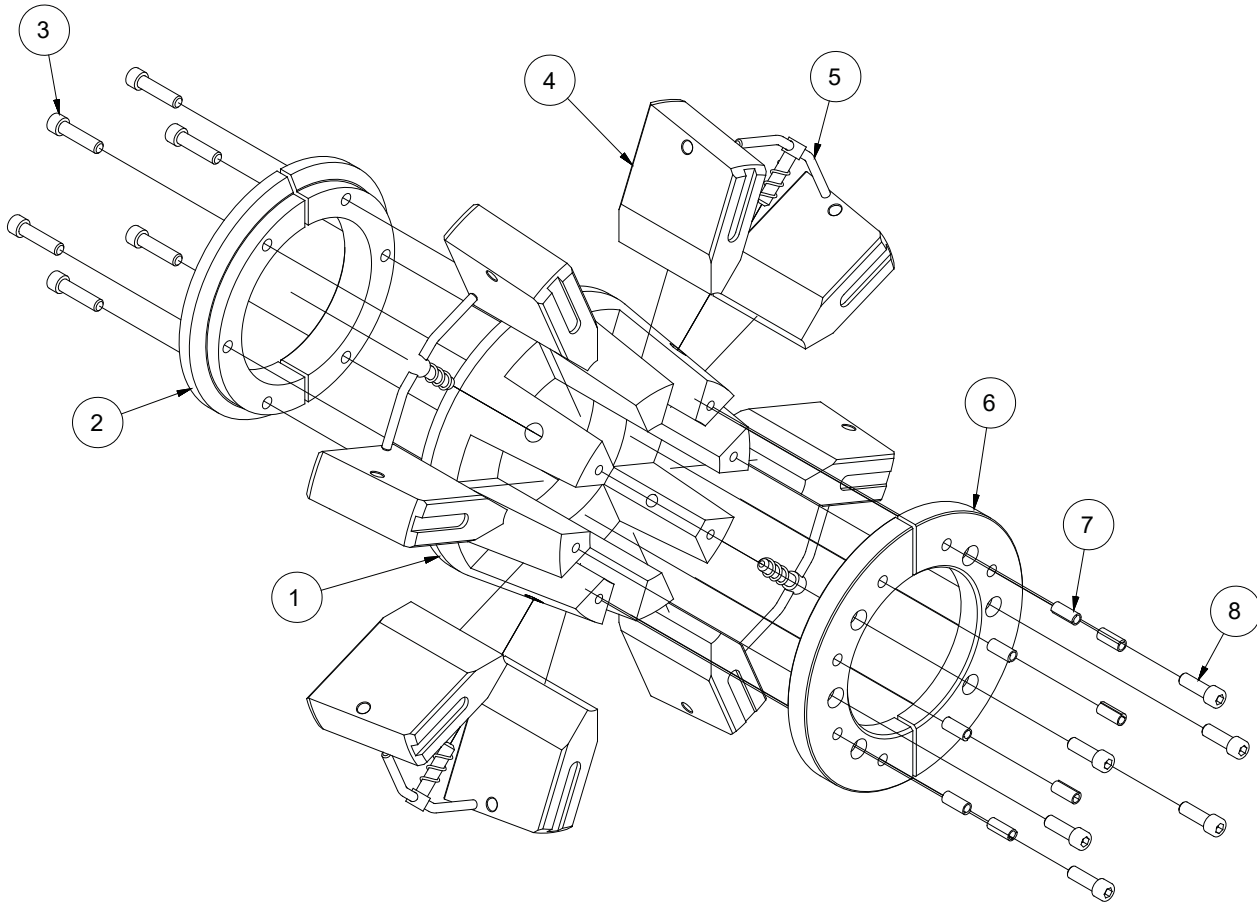

D305 Dies are available in both inch and metric sizes from 8mm (.315 in) to 96.5mm (3.80 in)

D305 - DIE ASSEMBLY (101700)			
ITEM	PART NUMBER	DESCRIPTION	QTY
1	101685	Short Die Guide	1
1	101686	Long Die Guide Option	1
2	101684	Die Guide Base	1
3	91251A542	1/4-20 x 1 SHCS	6
4	101697	8 Piece Short Die Finger Set	1
4	101698	8 Piece Long Die Finger Set Option	1
5	101696	Die Spring Retainer Assembly	4
6	101683	Die Retainer Ring	1
7	1/4 x 9/16	Spring Pin	8
8	91251A540	1/4-20 x 3/4 SHCS	6

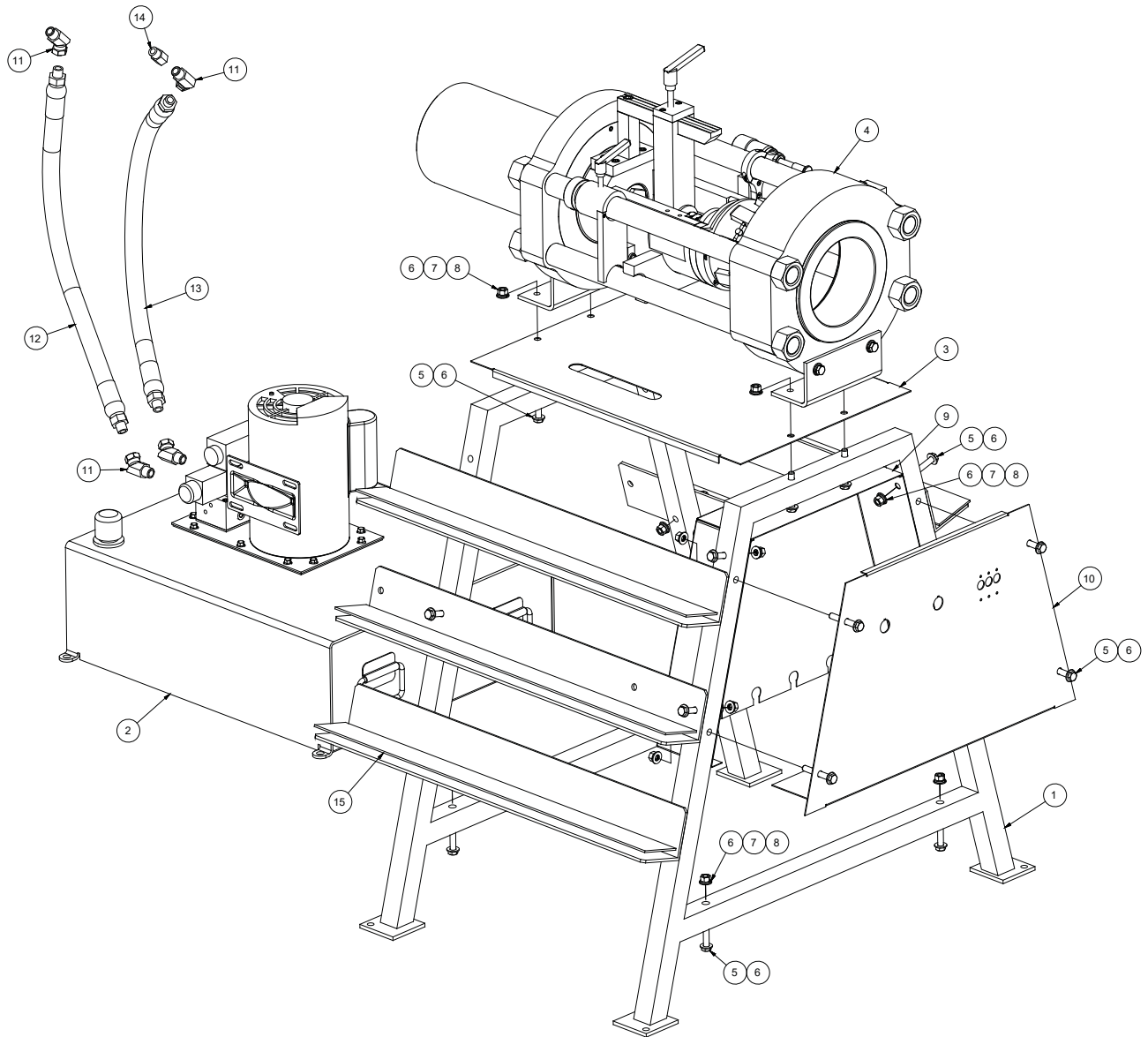

D305 - Crimper Assembly (101778)			
ITEM	PART NUMBER	DESCRIPTION	QTY
1	101775	D305 Crimper Stand Assembly	1
2	101782	D305 Pump/Motor/Reservoir Assembly	1
3	101783	D305 Stand Top Plate	1
4	101771	D305 Crimper Head Assembly	1
5	91247A634	3/8-16 x 2 1/2 HHCS	18
6	90108A417	3/8 Flat Washer	36
7	91102A760	3/8 Lock Washer	18
8	94895A031	3/8-16 Hex Nut	18
9	102123	D305 Electrical Box	1
10	102124	D305 Electrical Box Cover	1
11	60TA06X08	45 Deg. Hydraulic Fitting	4
12	101946	D305 Advance Hose	1
13	101948	D305 Retract Hose	1
14	0107-6-6	Straight Hydraulic Fitting	1
15	101929-30	D305 Shelf Pad	6

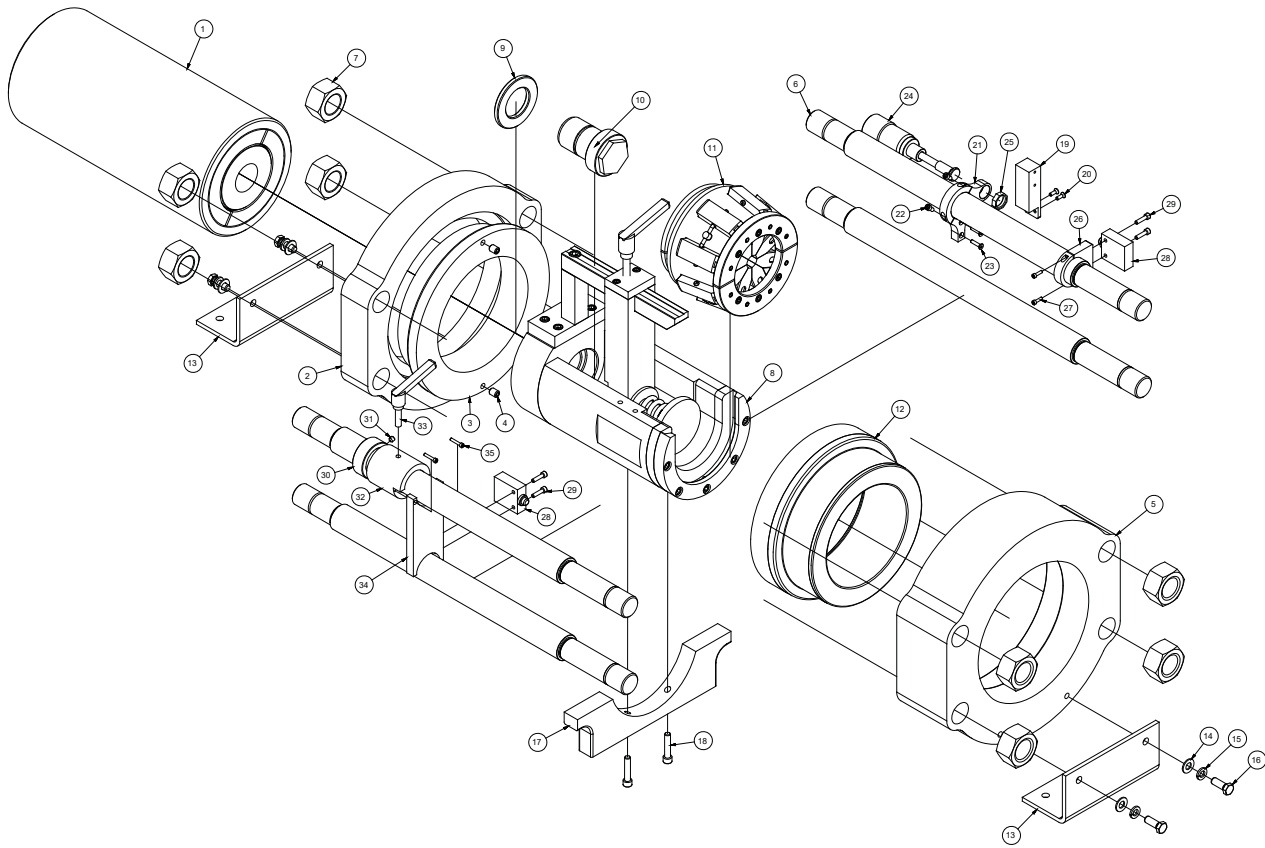

D305 - Crimper Head Assembly (101771)			
ITEM	PART NUMBER	DESCRIPTION	QTY
1	101842	100 Ton Cylinder Assembly	1
2	101758	Top Flange	1
3	102136	Top Flange Insert	1
4	91375A619	3/8-16 x 1/2 Set Screw	2
5	101757	Base Flange	1
6	101759	17" Strain Rod	4
7	90499A860	1 1/4-12 Hex Nut	8
8	101738	Die Cage/Coupling Stop Assembly	1
9	101768	Die Cage/Cylinder Spacer	1
10	101861	Die Cage/Cylinder Bolt	1
11	101700	Die Assembly	1
12	101756	Compression Cone Insert	1
13	100705	Mounting Bracket	2
14	90108A417	3/8 Flat Washer	4
15	91102A760	3/8 Lock Washer	4
16	92865A624	3/8-16 x 1 HHCS	4
17	101763	Die Cage Support Bracket	1
18	91251A587	5/16-18 x 1 1/2 SHCS	2
19	101764	Micrometer Support Bracket	1
20	91253A194	8-32 x 1/2 HSFHS	2
21	100672	Micrometer Bracket	1
22	91251A240	10-24 x 3/8 SHCS	2
23	91253A197	8-32 x 3/4 HSFHS	2
24	101752	2" Micrometer Assembly	1
25	100727	Micrometer Nut	1
26	101942	Advance Limit Switch Bracket	1
27	91251A148	6-32 x 1/2 SHCS	2
28	914CE1-6	Top Plunger Limit Switch	2
29	91251A245	10-24 x 3/4 SHCS	4
30	6436K23	Locking Collar	1
31	91375A533	1/4-20 x 1/4 Set Screw	1
32	101868	Auto Retract Bracket Top	1
33	KHA-122	Auto Retract Locking Handle	1
34	101867	Auto Retract Bracket	1
35	91251A151	6-32 x 3/4 SHCS	2

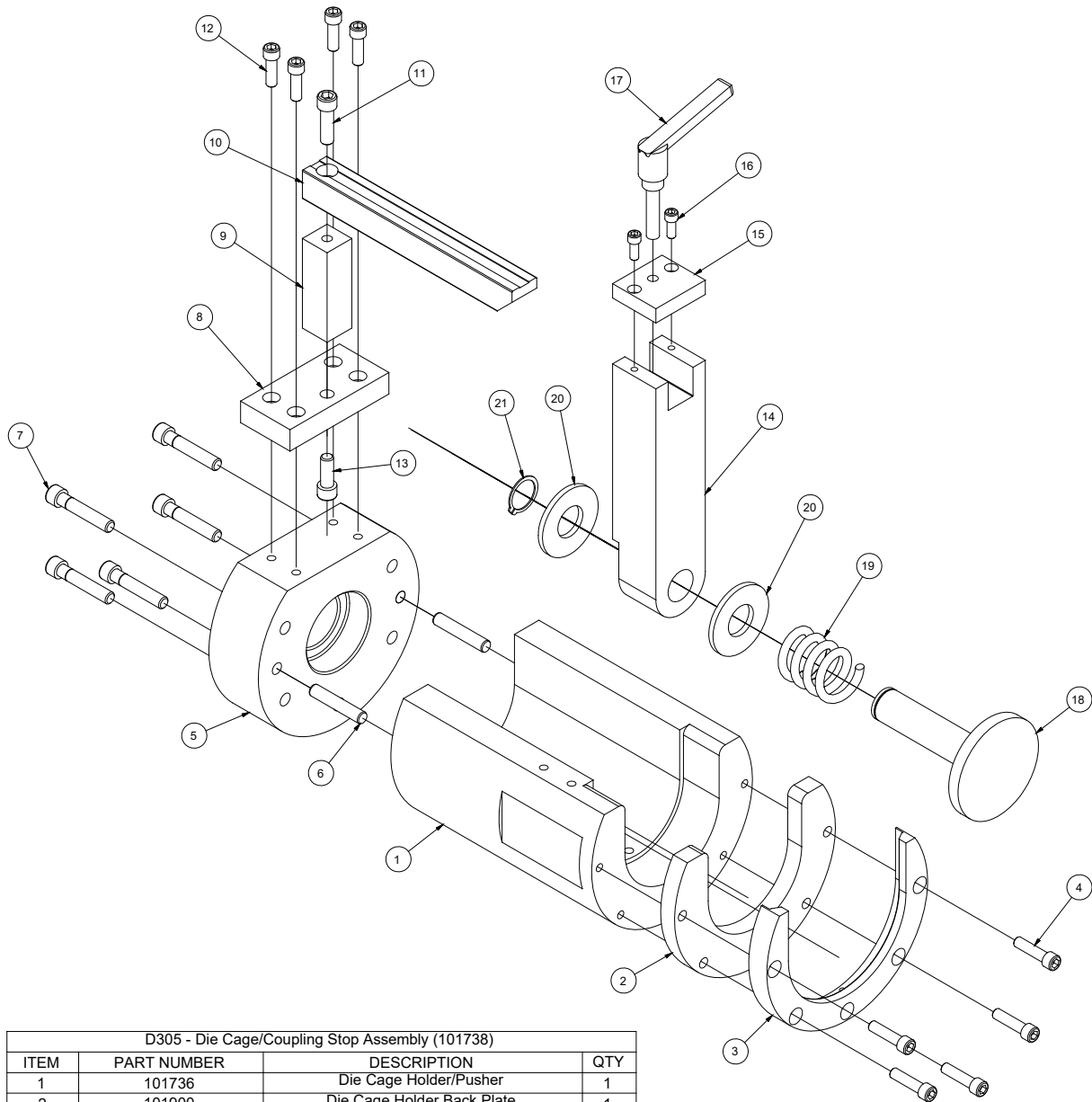

D305 - Die Cage/Coupling Stop Assembly (101738)			
ITEM	PART NUMBER	DESCRIPTION	QTY
1	101736	Die Cage Holder/Pusher	1
2	101900	Die Cage Holder Back Plate	1
3	101901	Die Cage Holder Front Plate	1
4	91251A587	5/16-18 x 1-1/2 SHCS	5
5	101735	Die Cage Back Plate	1
6	98372A435	Unhardened Ground Dowel Pin	2
7	91251A632	3/8-16 x 2 SHCS	5
8	101739	Coupling Stop Bracket Base	1
9	101765	Coupling Stop Bracket Support	1
10	101766	Coupling Stop Bracket Rail	1
11	91251A626	3/8-16 x 1-1/4 SHCS	1
12	91251A583	5/16-18 x 1 SHCS	4
13	91251A624	3/8-16 x 1 SHCS	1
14	101740	Coupling Stop Slide Bar Support	1
15	101741	Coupling Stop Slide Bar	1
16	91251A539	1/4-20 x 5/8 SHCS	2
17	KHA-150	Coupling Stop Locking Handle	1
18	101837	Coupling Stop Tube Assembly	1
19	LHC-177P-1M	Coupling Stop Spring	1
20	101753	Coupling Stop Flat Washer	2
21	98410A133	Coupling Stop 1" Retaining Ring	1

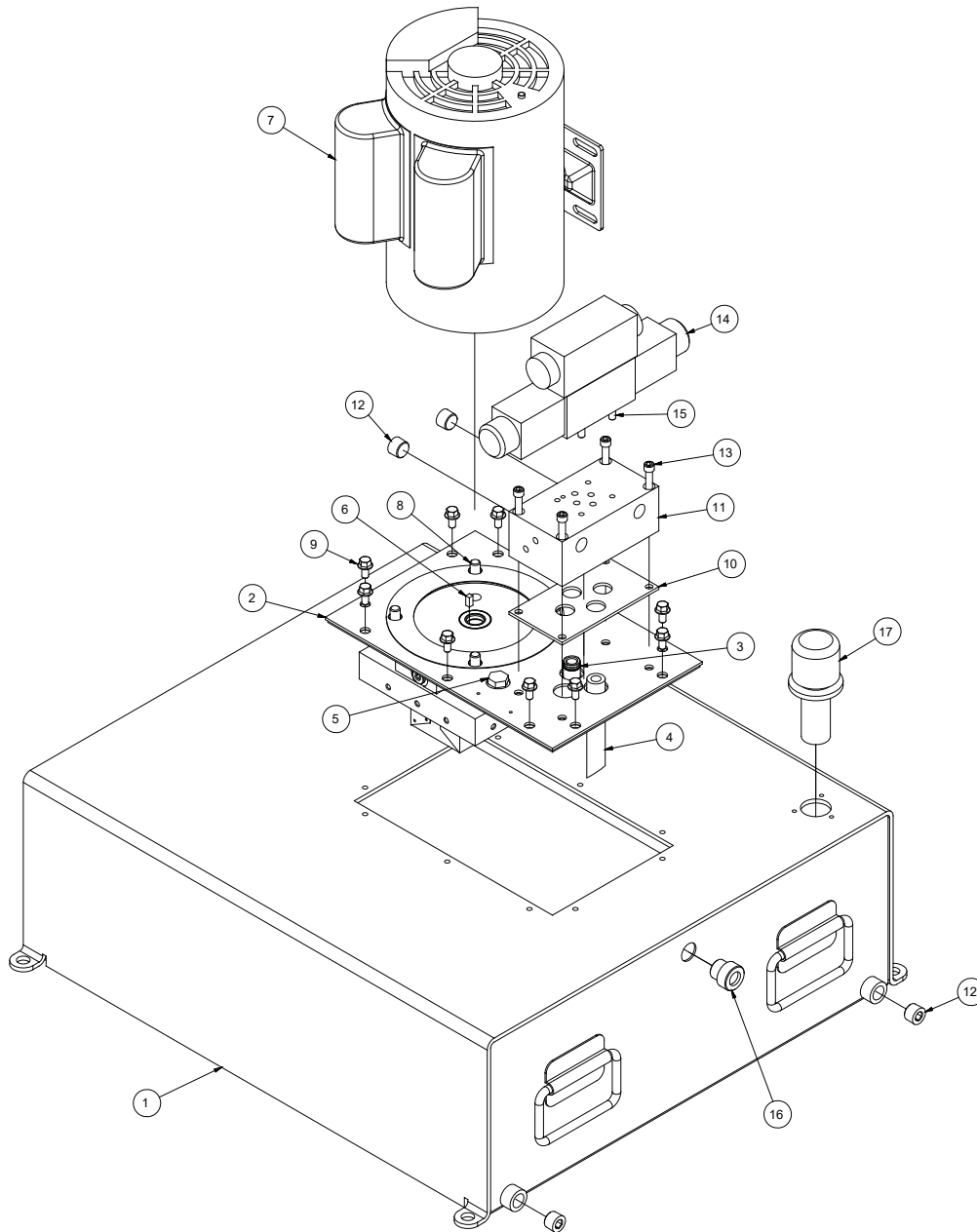

D305 - Pump/Motor/Reservoir Assembly (101782)			
ITEM	PART NUMBER	DESCRIPTION	QTY
1	101896	15-Gallon Reservoir	1
2	101884	3HP Pump Sub-Assembly	1
3	101394	Adaptor Assembly - 5/8 Dia.	1
4	101898	3/8 NPT Return Tube	1
5	101378	3/8-18 NPT Shipping Plug	1
6	101470	Square Shaft Key	1
7	101348	3HP Electric Motor	1
8	91251A623	3/8-16 x 7/8 SHCS	4
9	92323A512	1/4-20 x 1/2 HHFCS	10
10	101872	HP03 Manifold Gasket	1
11	101852	Pump Mount HP03 Manifold	1
12	101377	3/8-18 NPTF Pipe Plug	4
13	91251A551	1/4-20 x 2 1/4 SHCS	4
14	655011-HP03-24VDC	Directional Control Valve	1
15	91251A540	1/4-20 x 3/4 SHCS	4
16	LSP101-04	Sight Gauge	1
17	FCS-M	Filler/Breather	1

Custom Crimp®
Custom Machining Services, Inc.
326 N. County Rd. 400 East
Valparaiso, IN 46383
Ph: (219) 462-6128
Fax: (219) 464-2773
www.customcrimp.com



CustomCrimp®

See the complete line of CustomCrimp® Crimpers and Accessories at:
www.customcrimp.com

(219) 462-6128
